



Free Downloads of Build Instructions,
Assembly Booklets & How To Guides

BuildInstructions.com

WARHAMMER 40,000

CHAOS SPACE MARINES DEFILER

PROFANATEUR | PROFANADOR | GEISSEL | PROFANATORE | ディファイラー | 汚染者

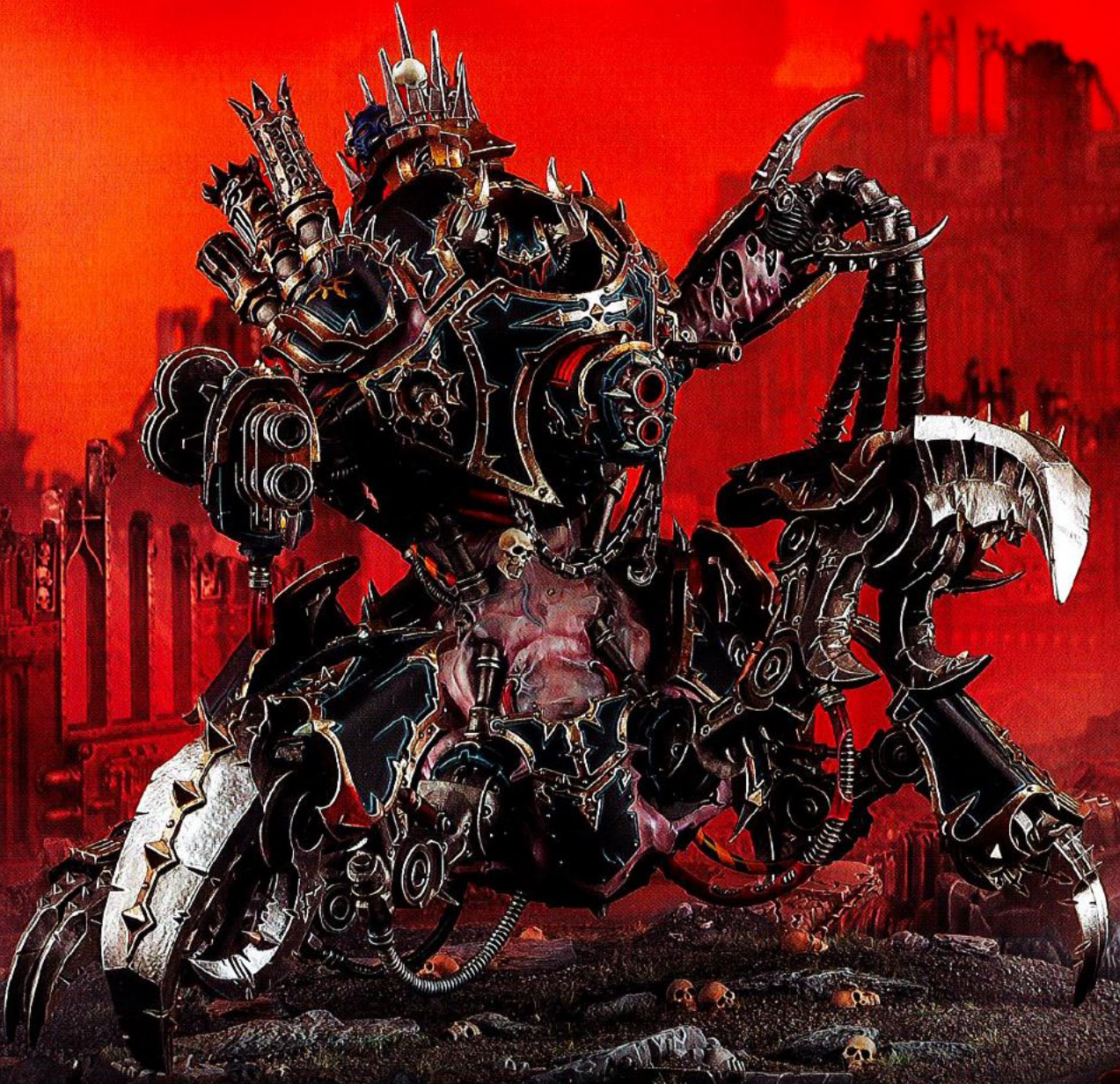



ENG BEFORE ASSEMBLING YOUR MINIATURES, PLEASE READ THROUGH THE INSTRUCTIONS IN THIS BOOKLET CAREFULLY. A pair of plastic cutters are required to remove the plastic components in this kit from their frame. We advise using a mouldline scraping tool to clean up the parts. To assemble your model you will need glue suitable for plastic models. We recommend you follow all instructions and warnings provided with any hobby accessories you purchase.

FRE AVANT D'ASSEMBLER VOS FIGURINES, VEUILLEZ LIRE ATTENTIVEMENT LES INSTRUCTIONS DE CE LIVRET. Une pince coupante est requise pour retirer chaque élément de sa grappe plastique. Nous vous conseillons d'utiliser un ébarboir pour faire disparaître les lignes de moulage. Pour assembler votre figurine, vous aurez besoin d'une colle spéciale pour le plastique. Nous vous recommandons de suivre les instructions et de respecter les mises en garde fournies avec les outils que vous achetez.

SPA POR FAVOR, LEE CUIDADOSAMENTE ESTE LIBRETO DE INSTRUCCIONES ANTES DE EMPEZAR A MONTAR LAS MINIATURAS. Te harán falta unas tenazas para plástico a fin de separar las piezas de la matriz. También aconsejamos una herramienta para rebabas a fin de limpiar cada pieza. Para montar la miniatura necesitarás pegamento para plástico. Recomendamos seguir las instrucciones y advertencias que figuren en los accesorios de hobby que vayas a emplear.

GER BEVOR DU DEINE MINIATUREN ZUSAMMENBAUST, BITTE LIES DIR DIE ANWEISUNGEN IN DIESEM BOOKLET SORGSAM DURCH. Du benötigst einen Kunststoffseitenschneider, um die Kunststoffteile aus diesem Bausatz aus ihrem Gussrahmen zu trennen. Wir empfehlen, einen Gussgratentferner zu verwenden, um die Teile zu säubern. Für den Zusammenbau deines Modells benötigst du für Kunststoffmodelle geeigneten Kleber. Wir empfehlen, dass du allen Anweisungen und Warnhinweisen folgst, die für all das Hobbyzubehör, das du kaufst, gelten.

ITA PRIMA DI ASSEMBLARE LE MINIATURE LEGGI CON ATTENZIONE LE ISTRUZIONI IN QUESTO LIBRETTO. Per rimuovere dallo sprue i componenti di plastica di questo kit è necessario un paio di tronchesine per plastica. Consigliamo l'utilizzo di un attrezzo per ripulire. Per assemblare il modello hai bisogno di colla idonea ai modelli di plastica. Consigliamo di seguire tutte le istruzioni e le avvertenze che accompagnano gli strumenti hobbistici acquistati.

日本語 ミニチュアを組み立てる前に、この冊子の説明をよくお読みください。このキットのプラスチック部品をフレームから取り外すには、プラスチック用カッターが必要です。パーツの表面を整えるには、モールドライン・スクレイピングツールを使用することをお勧めします。組み立てにはプラスチックミニチュア用の接着剤が必要です。購入したホビー用品に記載されているすべての指示と警告に従うことをお勧めします。

中文 在组装您的微缩模型之前，请仔细阅读本手册中的说明。您需要塑料剪钳才能从框架中取出板件中的塑料部件。我们建议使用合模线刮刀来清理零件。要组装您的模型，您还需要适合塑料模型的胶水。我们建议您遵循模型所附的所有说明和警告。

EXPLANATION OF SYMBOLS | EXPLICATION DES SYMBOLES | EXPLICACIÓN DE SÍMBOLOS | ERLÄUTERUNG DER SYMBOLE | LEGENDA DEI SIMBOLI | アイコン解説 | 符号说

- | | | | |
|---|---|--|--|
| <p> • Special instruction - take care</p> <p> • Instruction spéciale - faites attention</p> <p> • Instrucciones especiales - presta atención</p> <p> • Besondere Anweisung - bitte beachten</p> <p> • Istruzioni speciali: prestare attenzione</p> <p> • 特記事項 - 要注意</p> <p> • 特别说明 - 小心</p> | <p> • Do not glue the components</p> <p> • Ne pas coller les éléments</p> <p> • No pegar los componentes</p> <p> • No pegar los componentes</p> <p> • Bitte die Teile nicht kleben</p> <p> • Non incollare i componenti</p> <p> • このパーツは接着不可</p> <p> • 请勿粘接</p> | <p> • Use matching parts</p> <p> • Utiliser les éléments correspondants</p> <p> • Usa las piezas que correspondan</p> <p> • Use matching parts</p> <p> • Utiliser les éléments correspondants</p> <p> • Usa las piezas que correspondan</p> <p> • Verwende die passenden Teile</p> <p> • Usa le parti corrispondenti</p> <p> • 適合するパーツを使用</p> <p> • 使用匹配部件</p> | <p> • Variant assembly</p> <p> • Variante d'assemblage</p> <p> • Variante de montaje</p> <p> • Bauvariante</p> <p> • Assemblaggio alternativo</p> <p> • 組み立てバリエーション</p> <p> • 多种组装方式</p> <p> • Choice of parts</p> <p> • Choix d'éléments</p> <p> • Piezas opcionales</p> <p> • Auswahl an Teilen</p> <p> • Scelta di componenti</p> <p> • パーツの選択</p> <p> • 选择部件</p> |
| <p> • Dry fit stage before gluing</p> <p> • Tester avant de coller</p> <p> • Comprobar el encaje antes de pegar</p> <p> • Positionierung erst ohne Klebstoff ausprobieren</p> <p> • Prova a secco prima di incollare</p> <p> • 接着前にぴったり合わせる</p> <p> • 粘接前的假组阶段</p> | <p> • Paint before assembly</p> <p> • Peindre avant assemblage</p> <p> • Pintar antes del montaje</p> <p> • Erst bemalen, dann zusammenbauen</p> <p> • Dipinti prima dell'assemblaggio</p> <p> • 組み立て前にペイントすること</p> <p> • 组装前涂装</p> | <p> • Assembly sequence</p> <p> • Séquence d'Assemblage</p> <p> • Secuencia de montaje</p> <p> • Baureihenfolge</p> <p> • Sequenza di assemblaggio</p> <p> • 組み立て手順</p> <p> • 拼装顺序</p> | <p> • Trim Parts - Cut as shown</p> <p> • Retirer les Pièces - Coupez comme indiqué</p> <p> • Cortar piezas - Corta del modo indicado</p> <p> • Teile abtrennen - Wie abgebildet schneiden</p> <p> • Taglia i componenti - Taglia dove indicato</p> <p> • パーツの切り取り - 見本通りに切り取る</p> <p> • 需要修整的组件 - 如说明所示进行削切</p> |

BUILD VARIANTS | VARIANTES D'ASSEMBLAGE | VARIANTES DE MONTAJE | BAUVARIANTEN | VARIANTI D'ASSEMBLAGGIO | バリエーション | 变体版

- | | |
|---|--|
| <p> • Assemblies for build variants are colour coded.</p> <p> • Les variantes d'assemblage ont un code couleur.</p> <p> • Las instrucciones para montajes alternativos se indican con un color diferente.</p> <p> • Optionen für Bauvarianten sind farblich markiert.</p> | <p> • Le diverse varianti d'assemblaggio sono divise per colore.</p> <p> • バリエーション違いの組み立ては色分けされている。</p> <p> • 变体版拼装部件有颜色区分</p> |
|---|--|

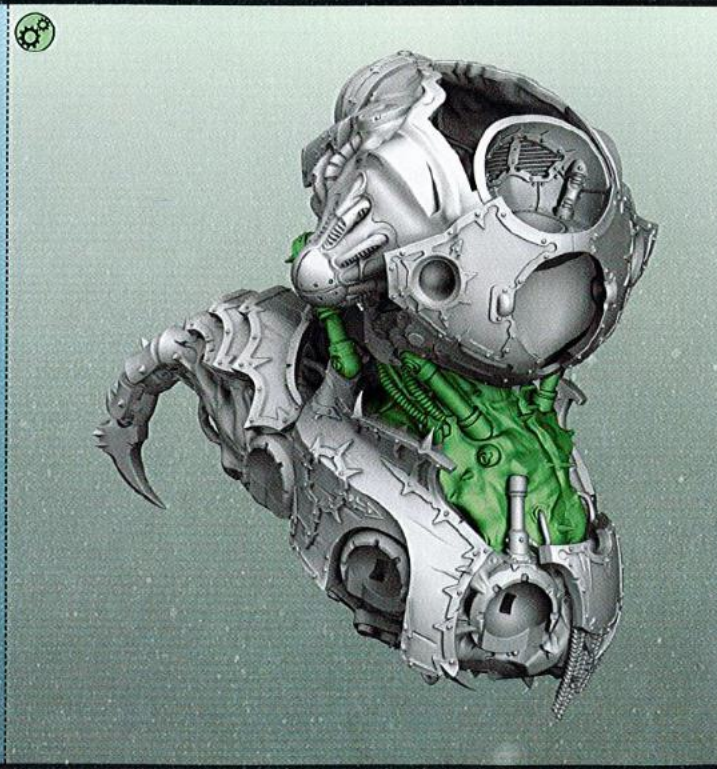

1 a

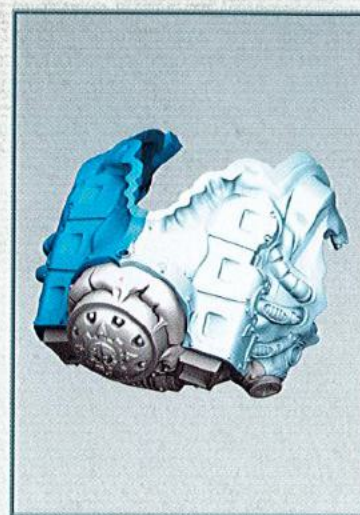
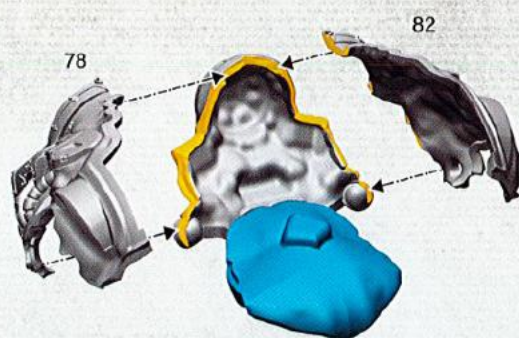
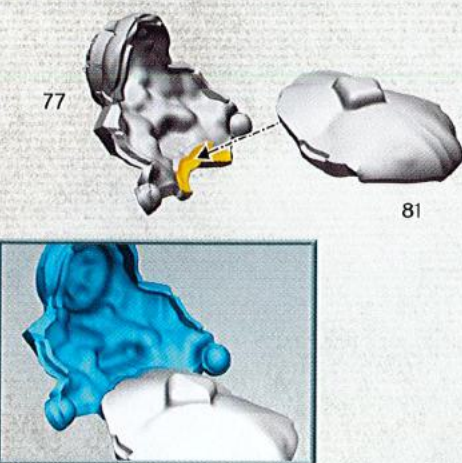

1 b

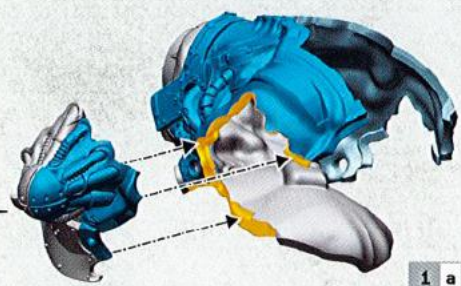
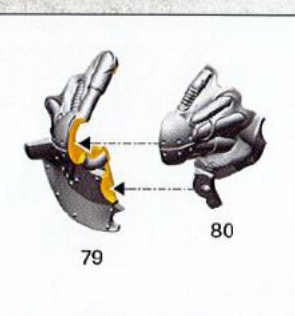

1 a

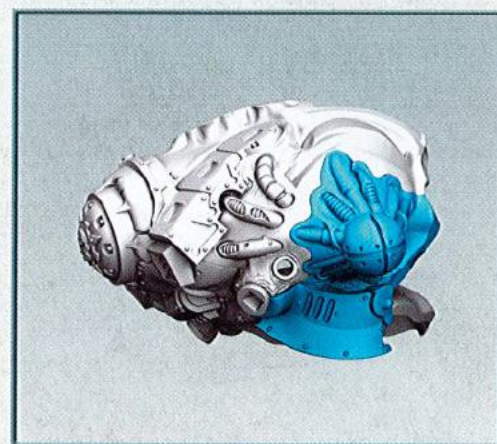

1 c

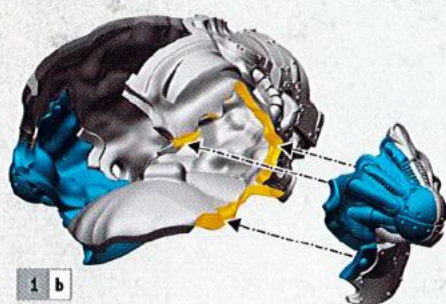

1 b

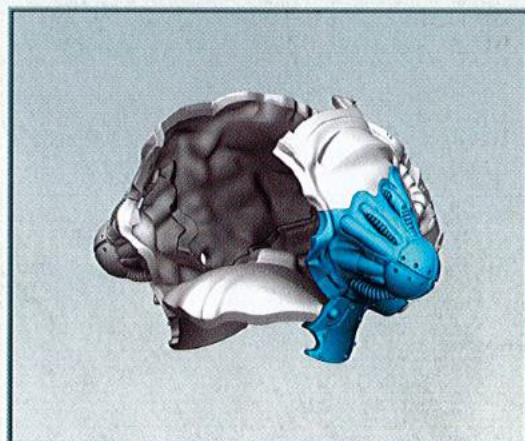
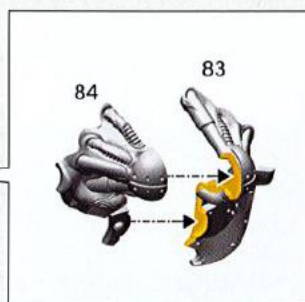

1 d

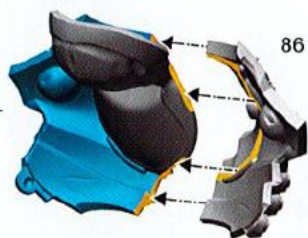

86

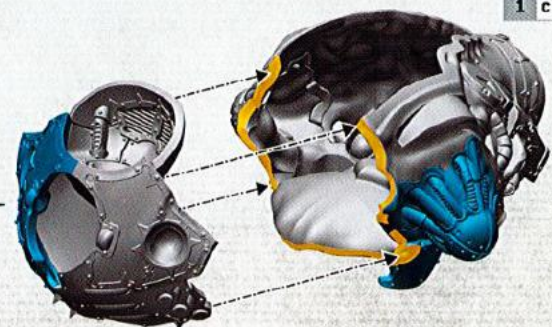

1 c

- Choose the variant you want to build
- Choisissez la variante à assembler
- Elige qué versión quieres montar
- Wähle die Variante, die du bauen möchtest

- Scegli la variante che vuoi assemblare
- 組み立てバリエーションの選択
- 选择你喜欢的拼装方式



2 a

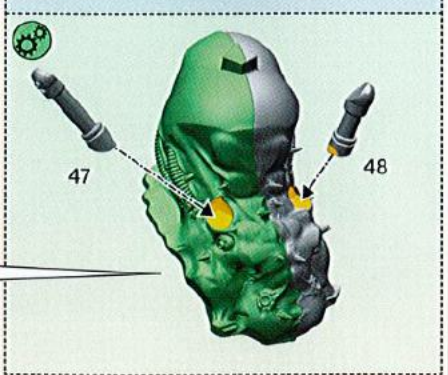
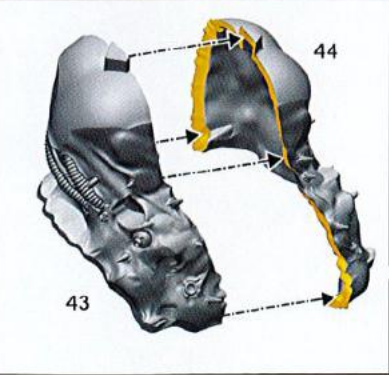
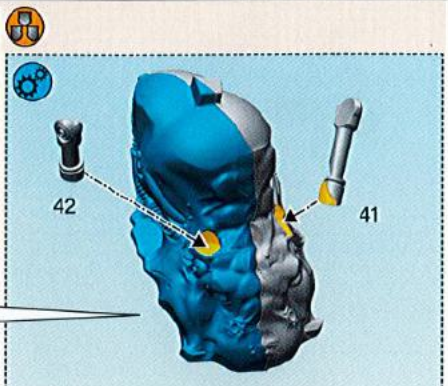
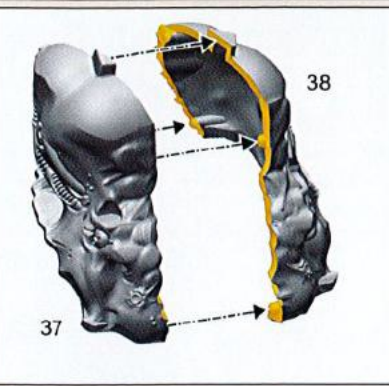
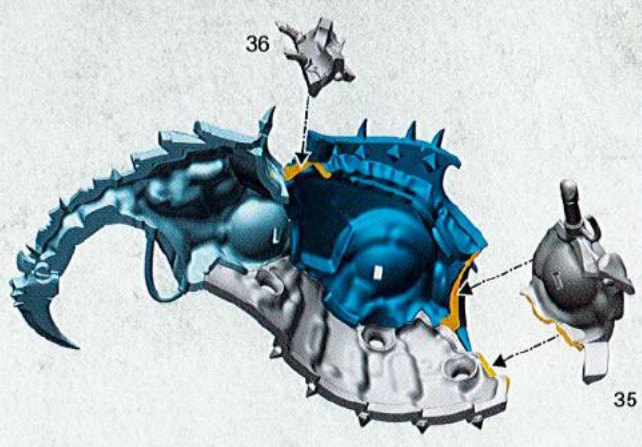
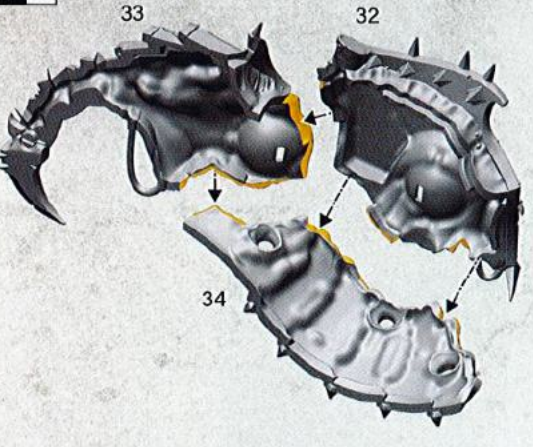

2 b



2 a

2 c

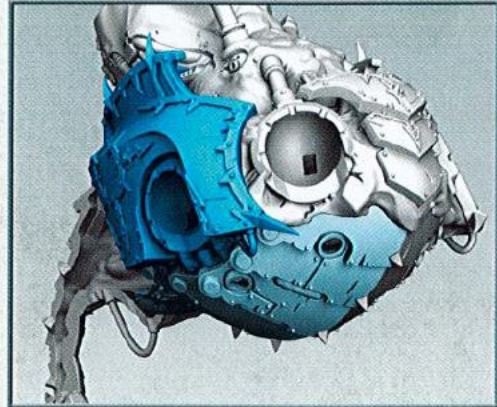
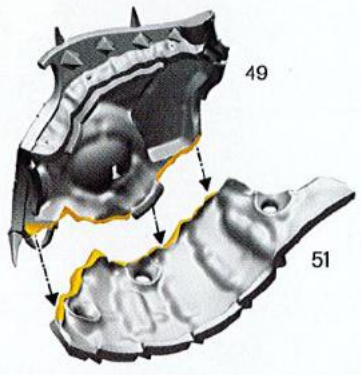
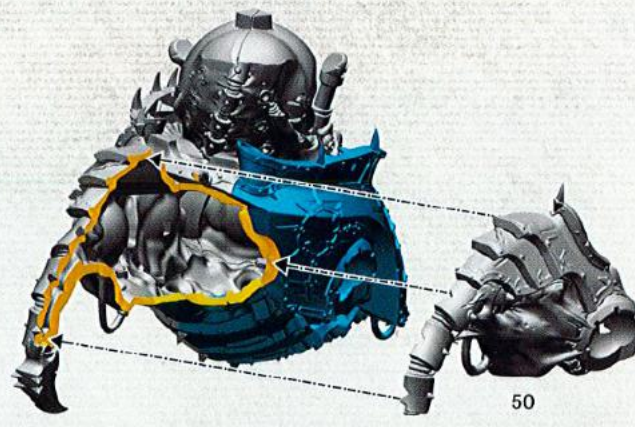
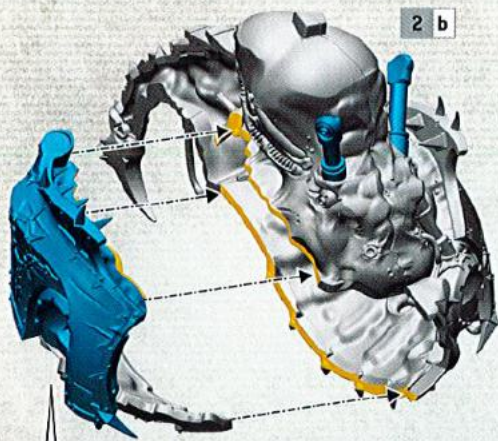

2 d

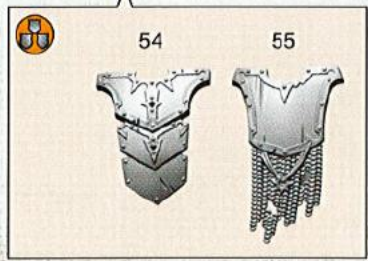
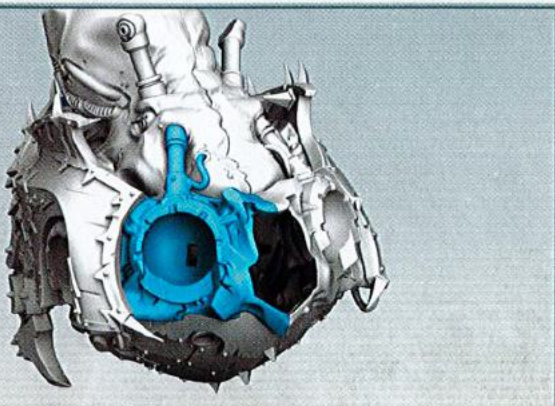
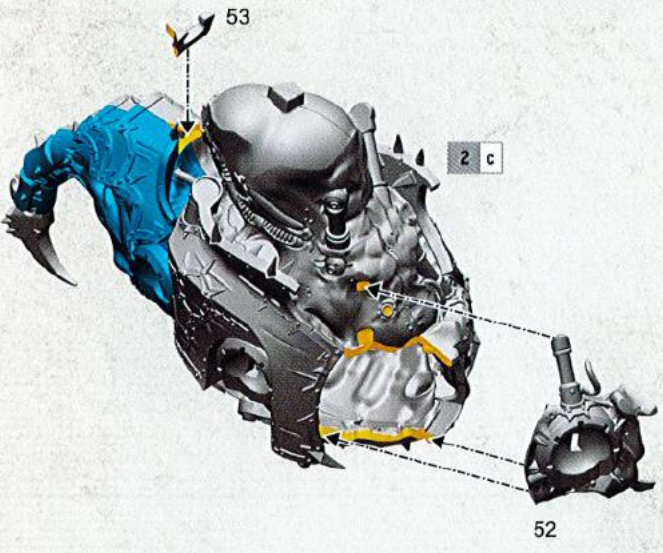

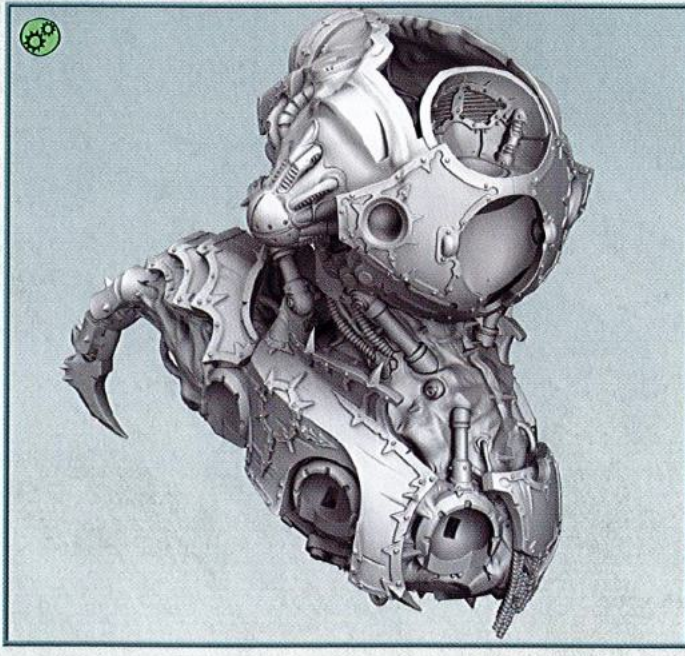
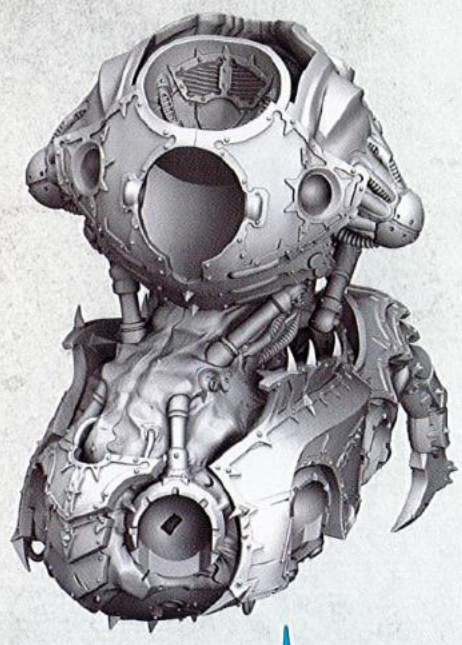
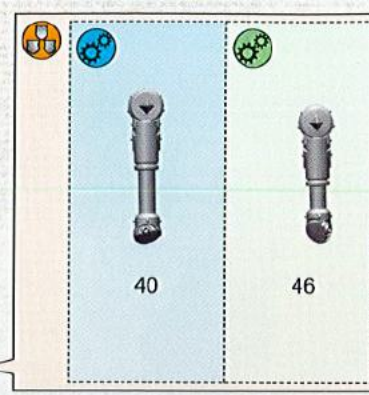
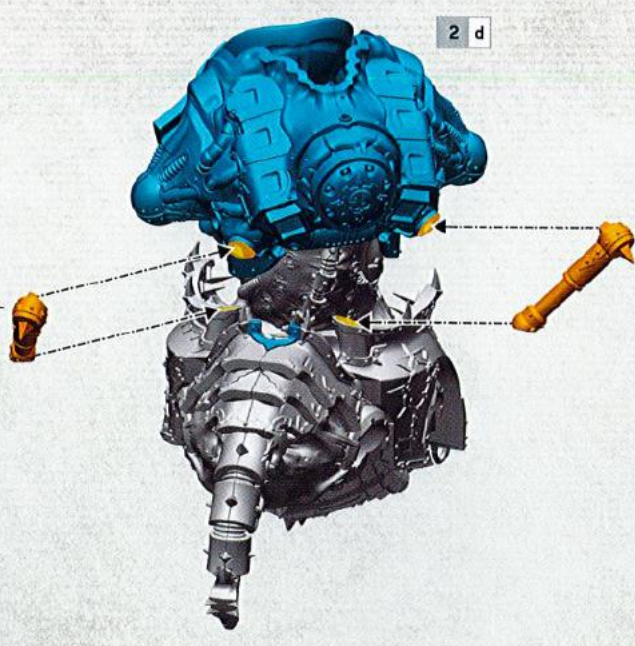
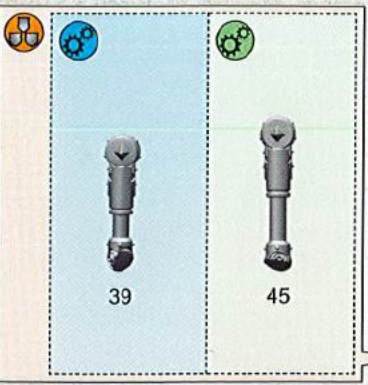

3



4



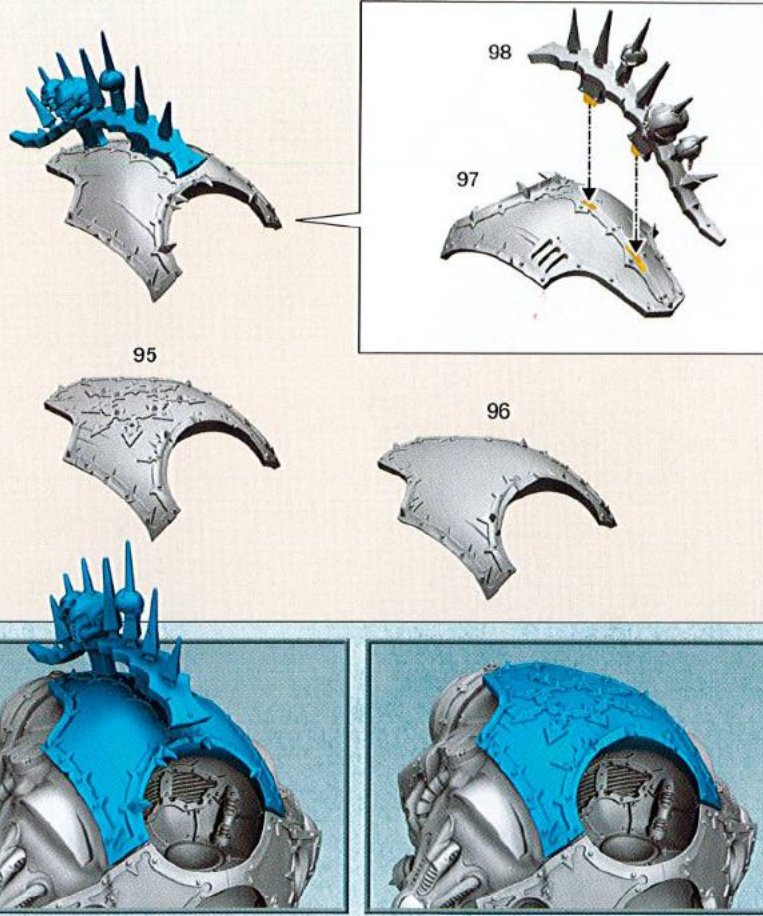
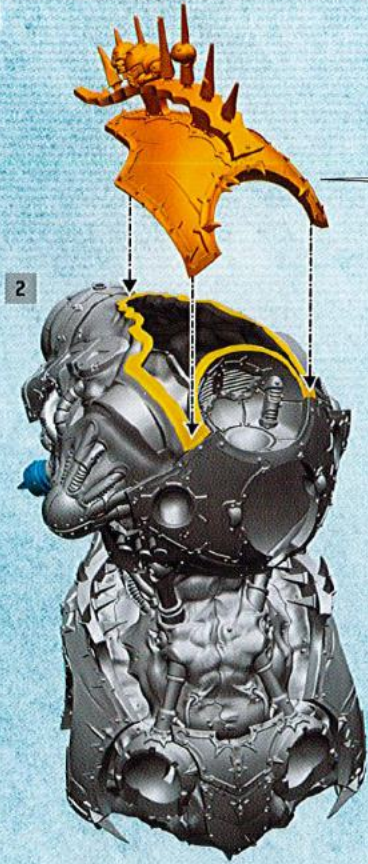

3 a

<p>155</p>	<p>156</p>	<p>158</p>	<p>160</p>	<p>159</p>
<p>157</p>		<p>168</p>		
<p>Iron Warriors Guerreros de Hierro アイアンウォリアー 钢铁战士</p>		<p>Word Bearers Portadores de la Palabra ワードベアラー 怀言者</p>		
<p>165</p>		<p>166</p>		
<p>World Eaters Devoradores de Mundos ワールドイーター 吞世者</p>		<p>Thousand Sons Mil Hijos サウザンド・サン 千子</p>		
<p>Emperor's Children Hijos del Emperador エンペラーズ・チルドレン 帝皇之子</p>		<p>Death Guard Guardia de la Muerte デスガード 死亡守卫</p>		
<p>161</p>			<p>163</p>	

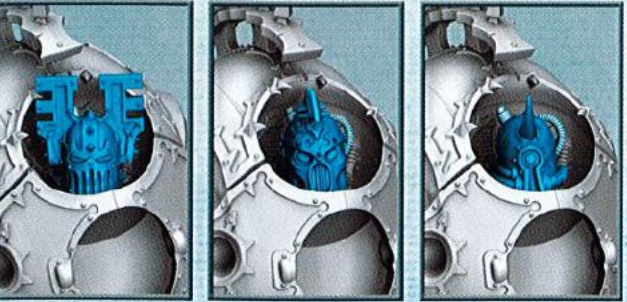

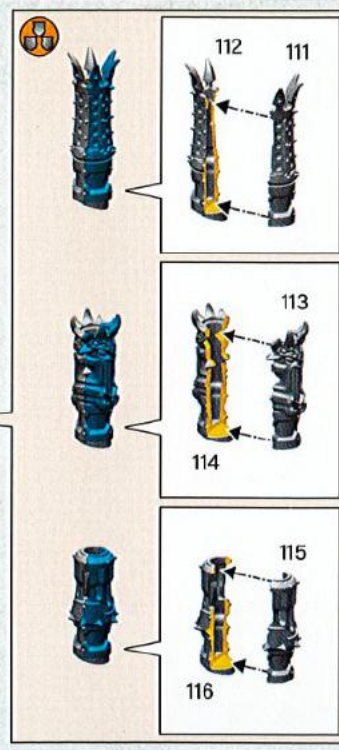
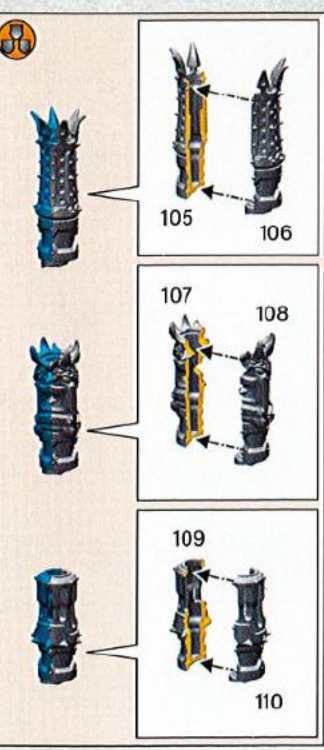

5 b

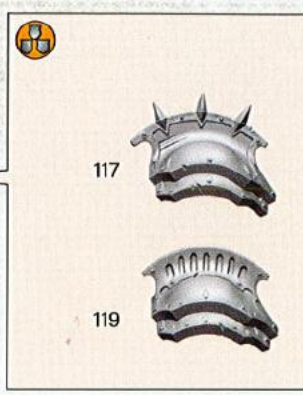
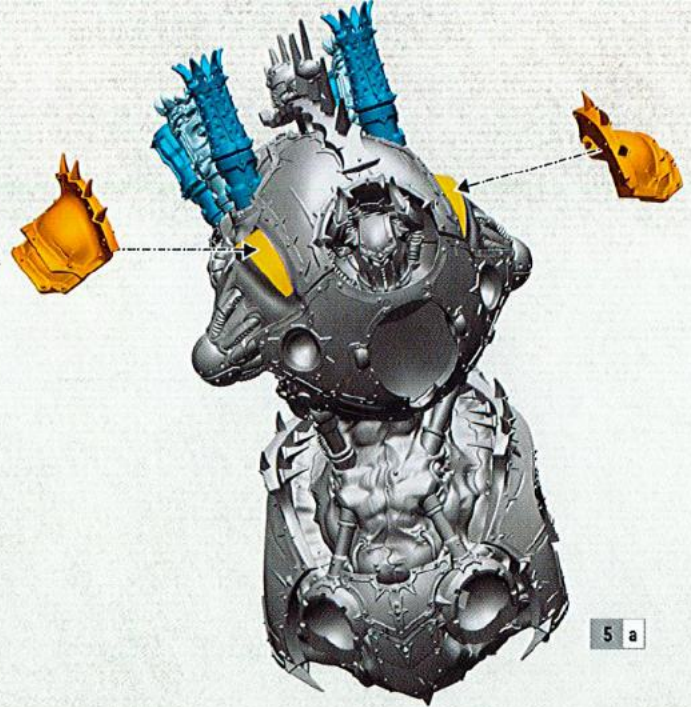
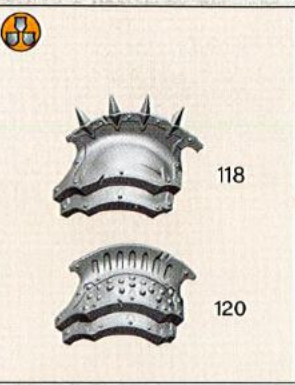

5 c

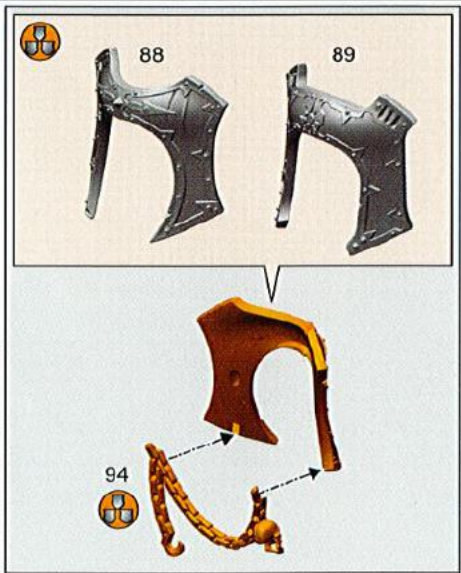
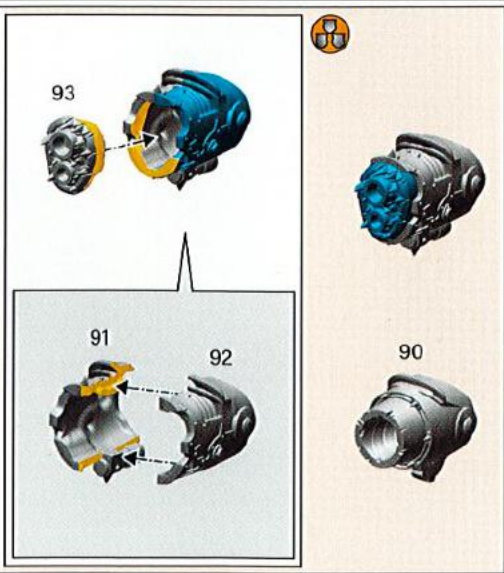
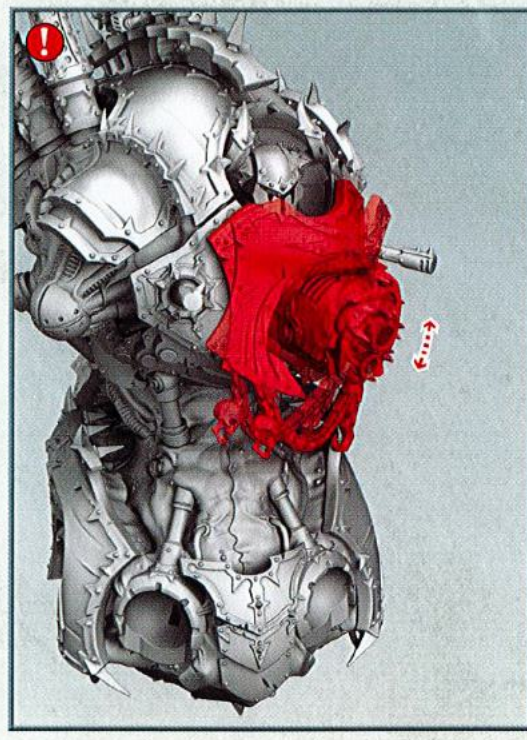
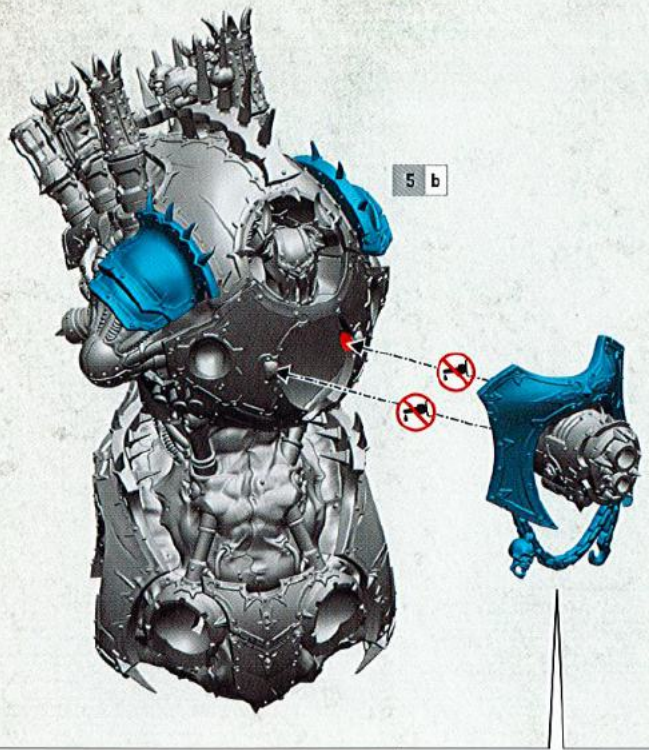

5 d

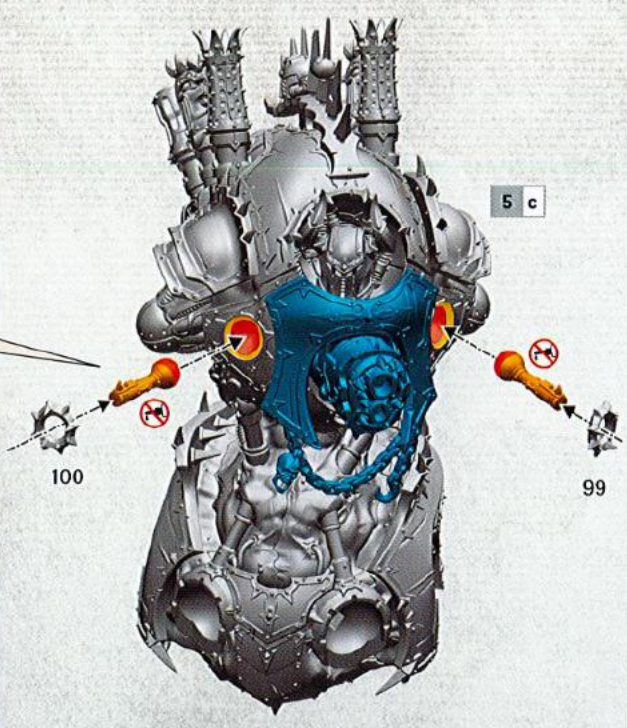
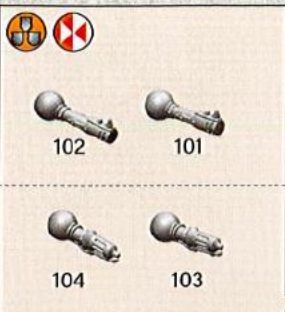

6-12

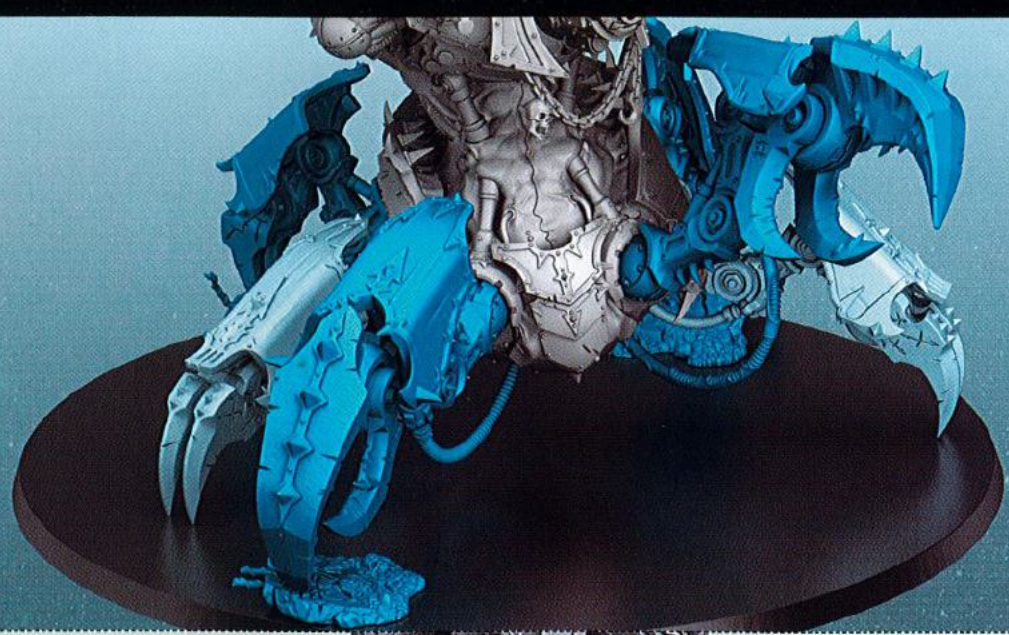

13-19

- Advanced Build
- Assemblage Avancé
- Montaje avanzado
- Fortgeschrittene Bauvariante
- Assemblaggio avanzato
- 高度な組み立て
- 进阶组装

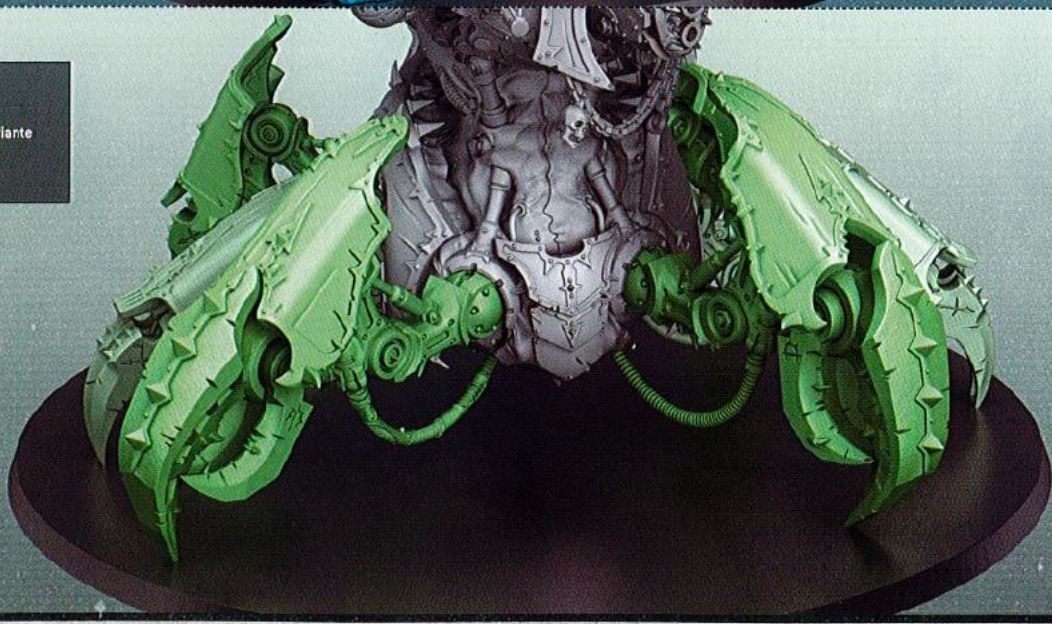

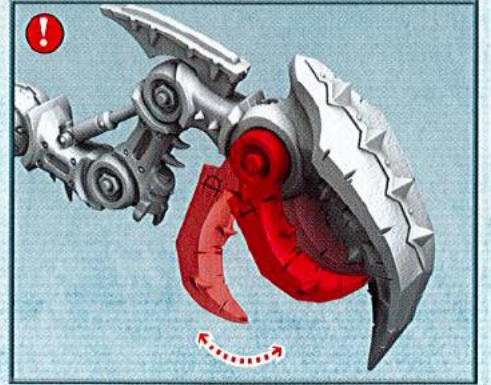
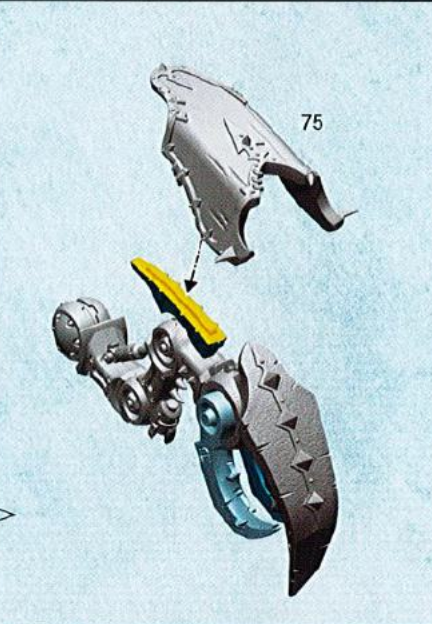
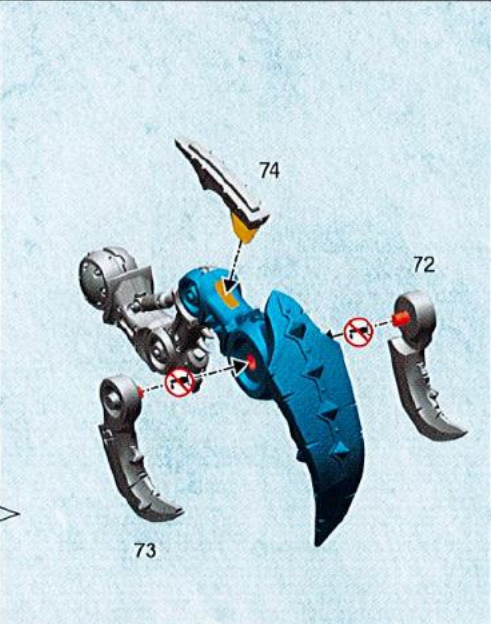
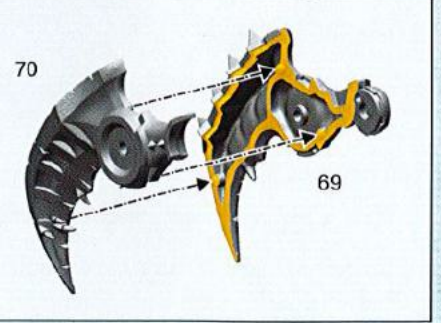
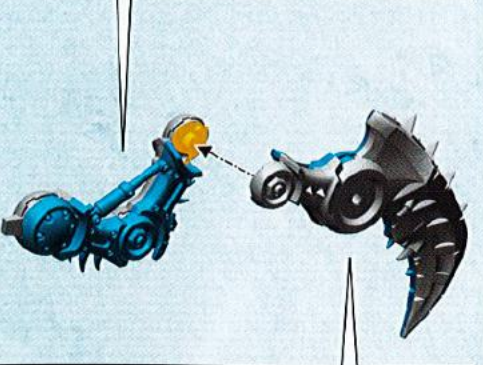
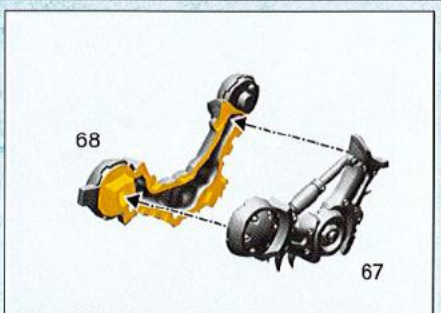
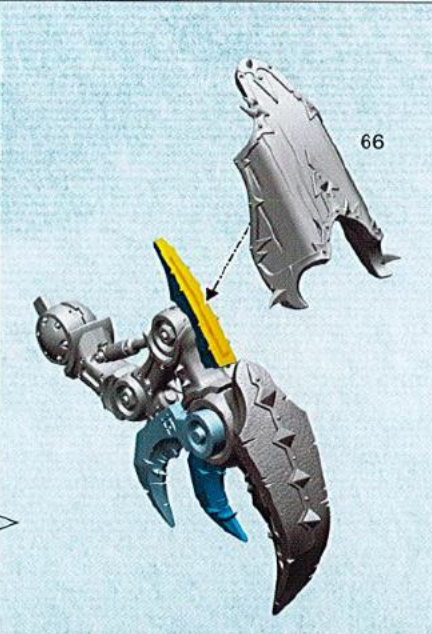
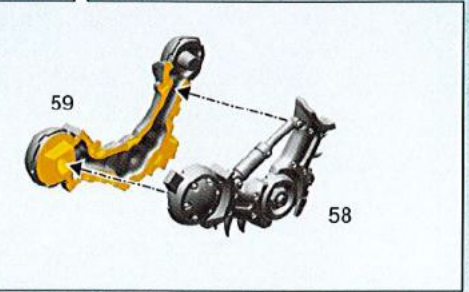
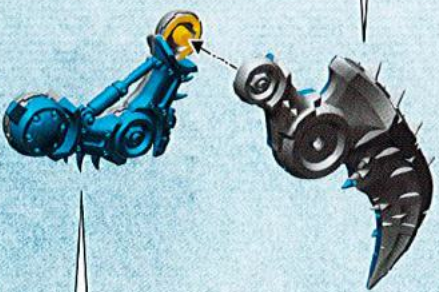
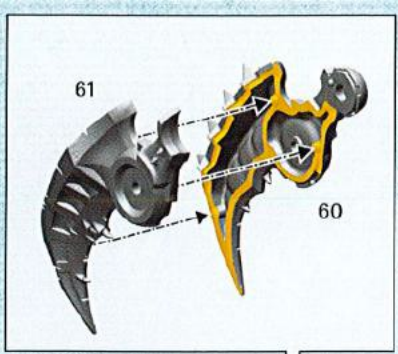

8

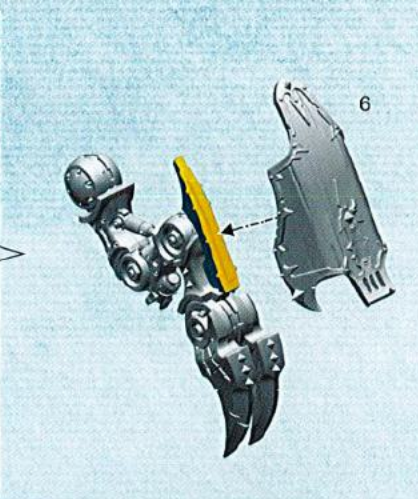
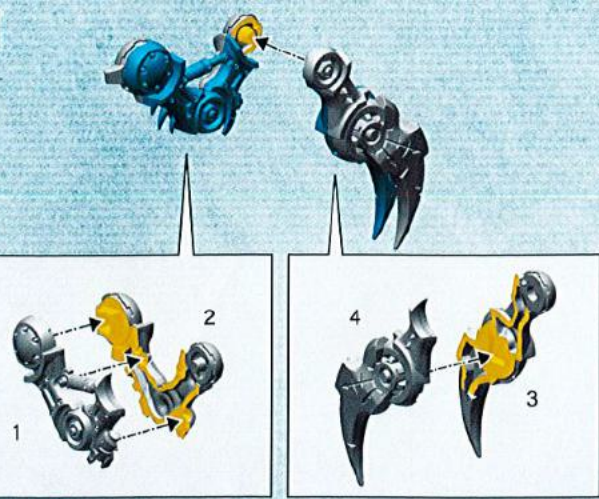

9

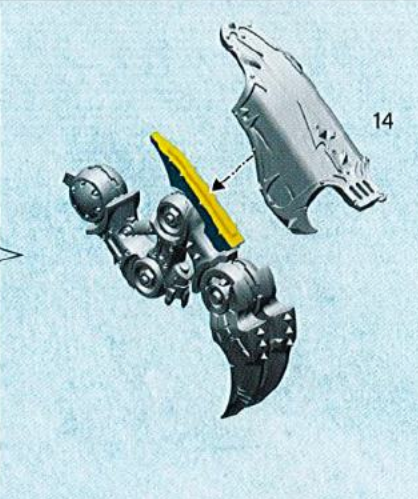
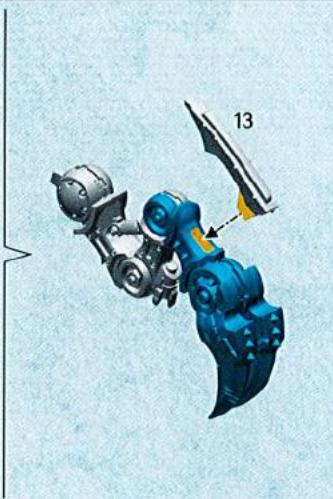
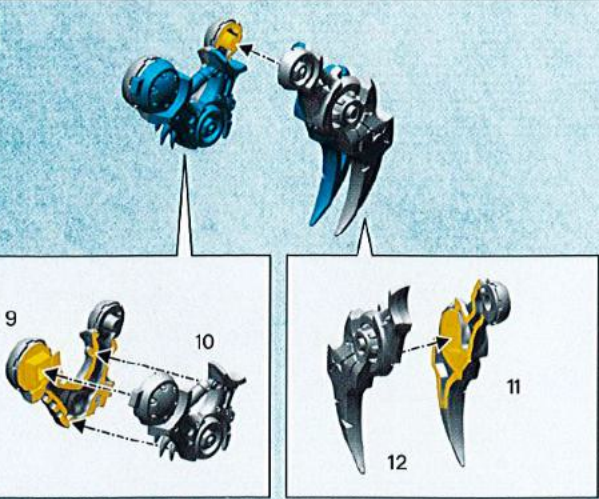

10

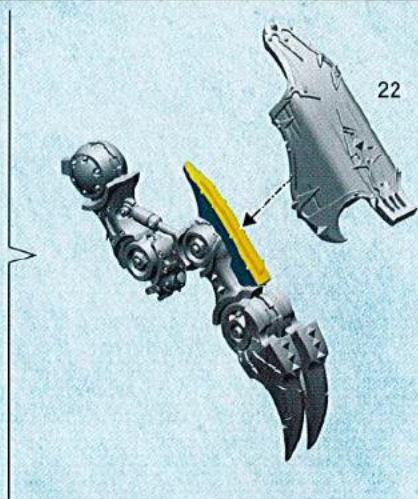
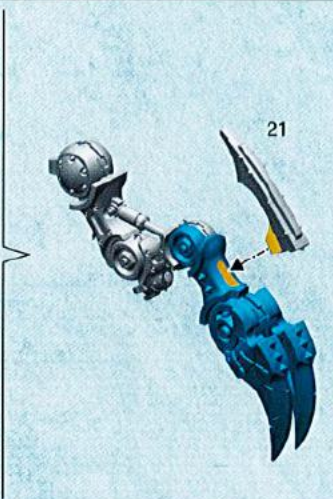
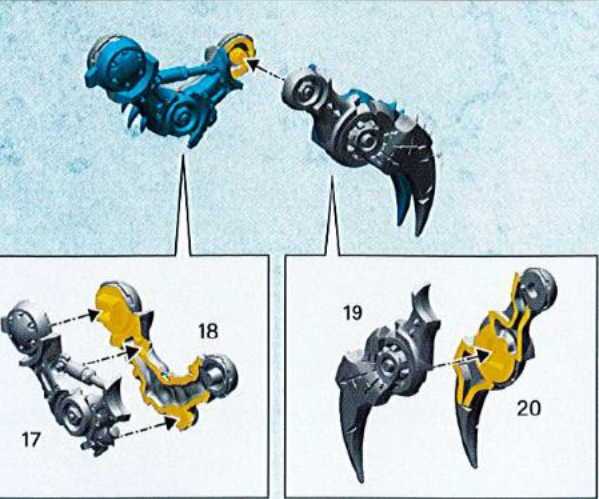

11

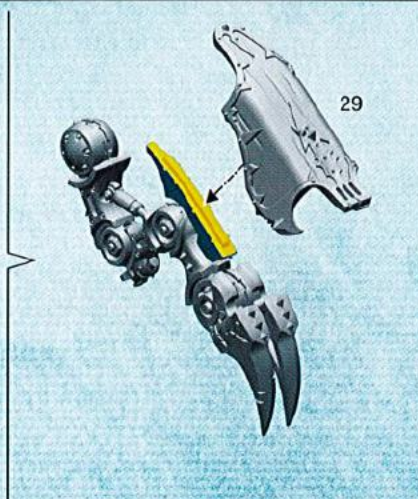
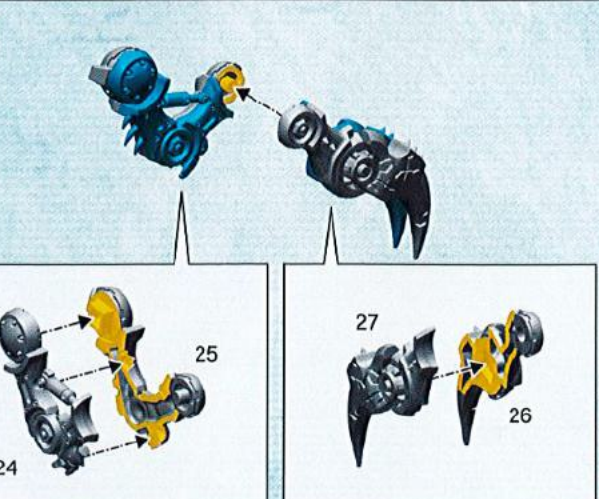

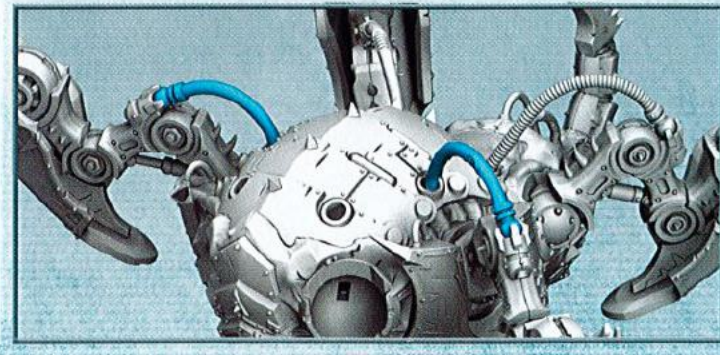
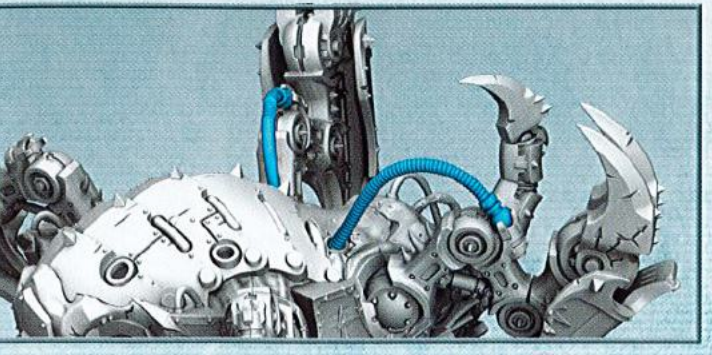
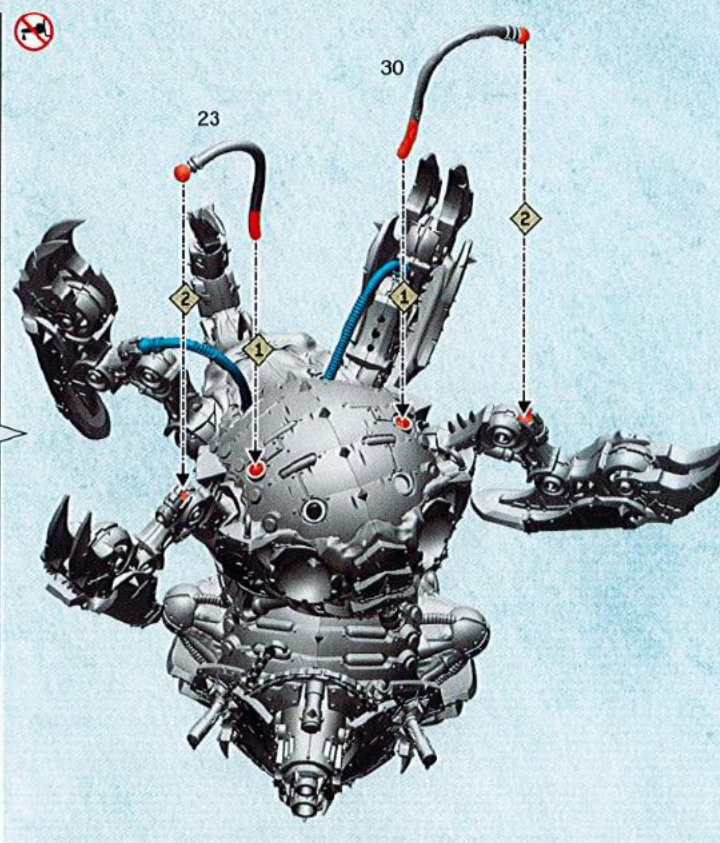
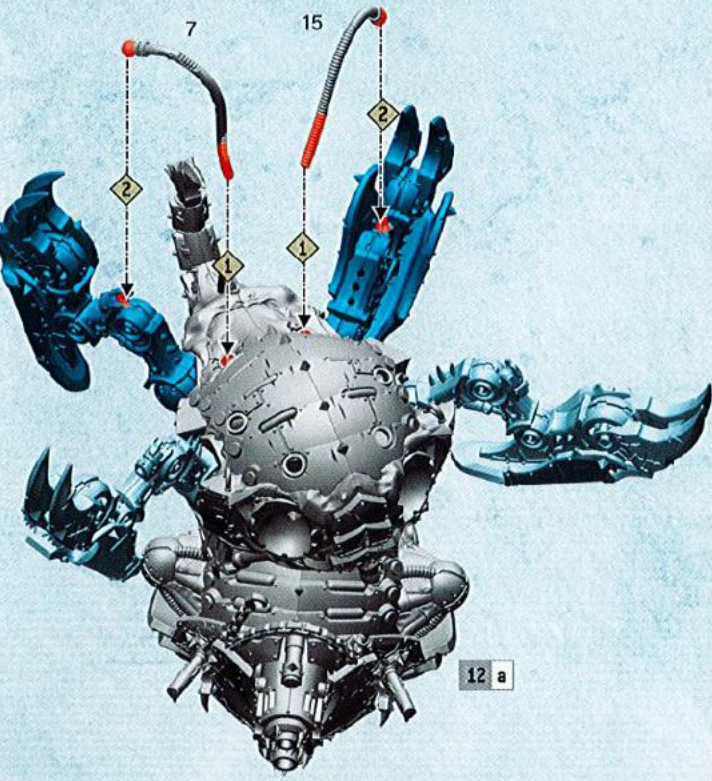

12 c

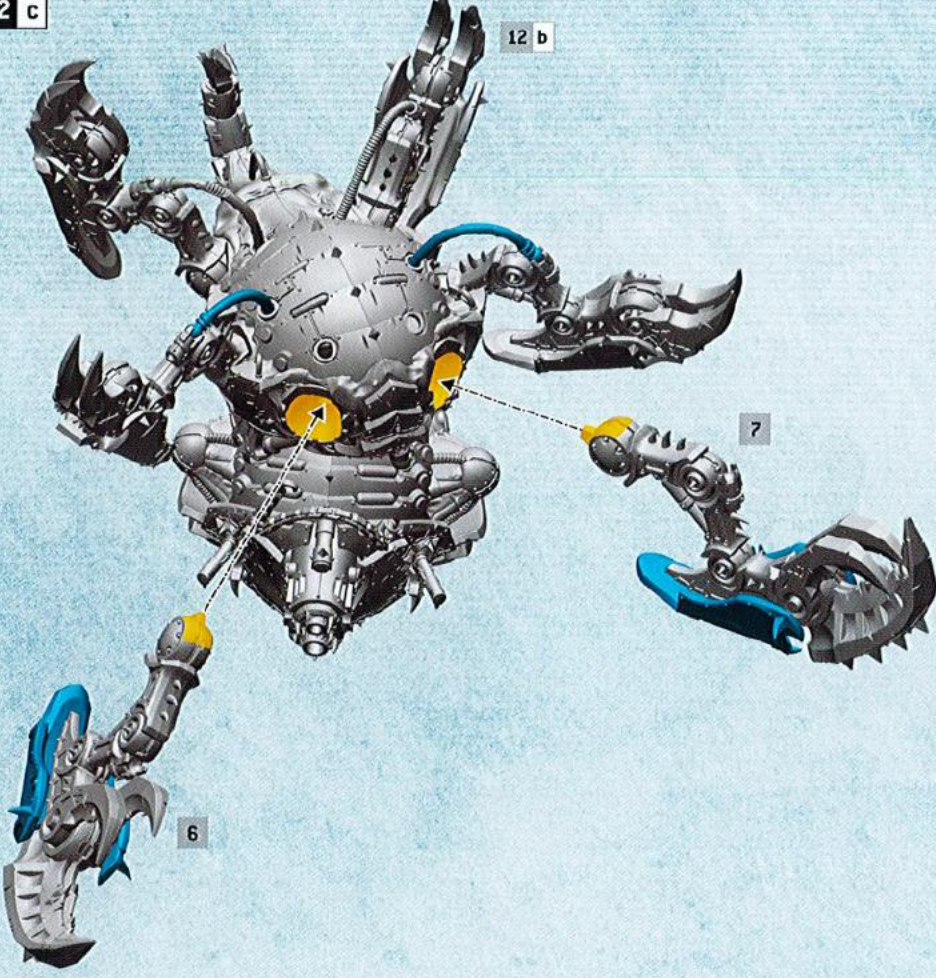

12 d

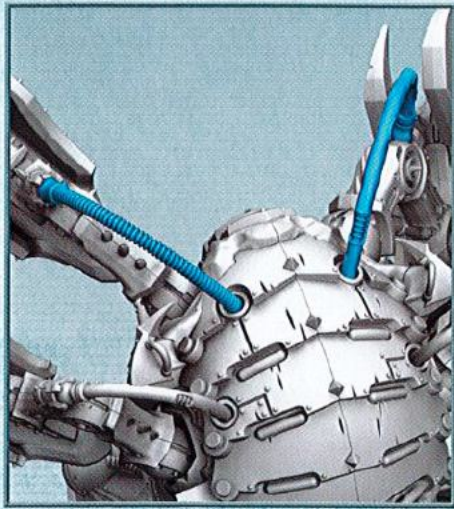
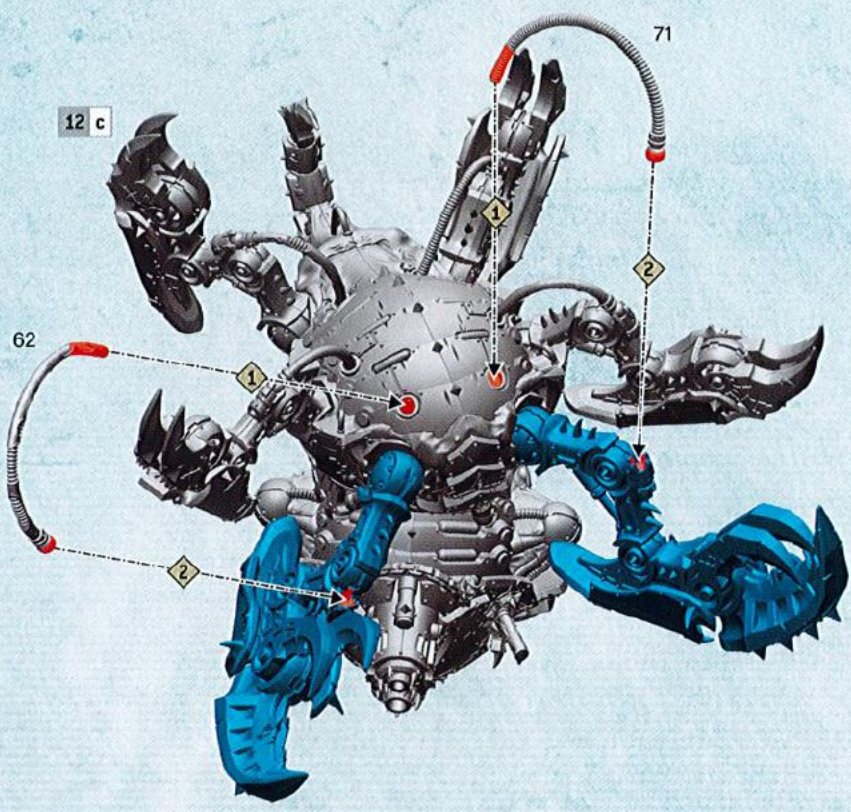

12 d

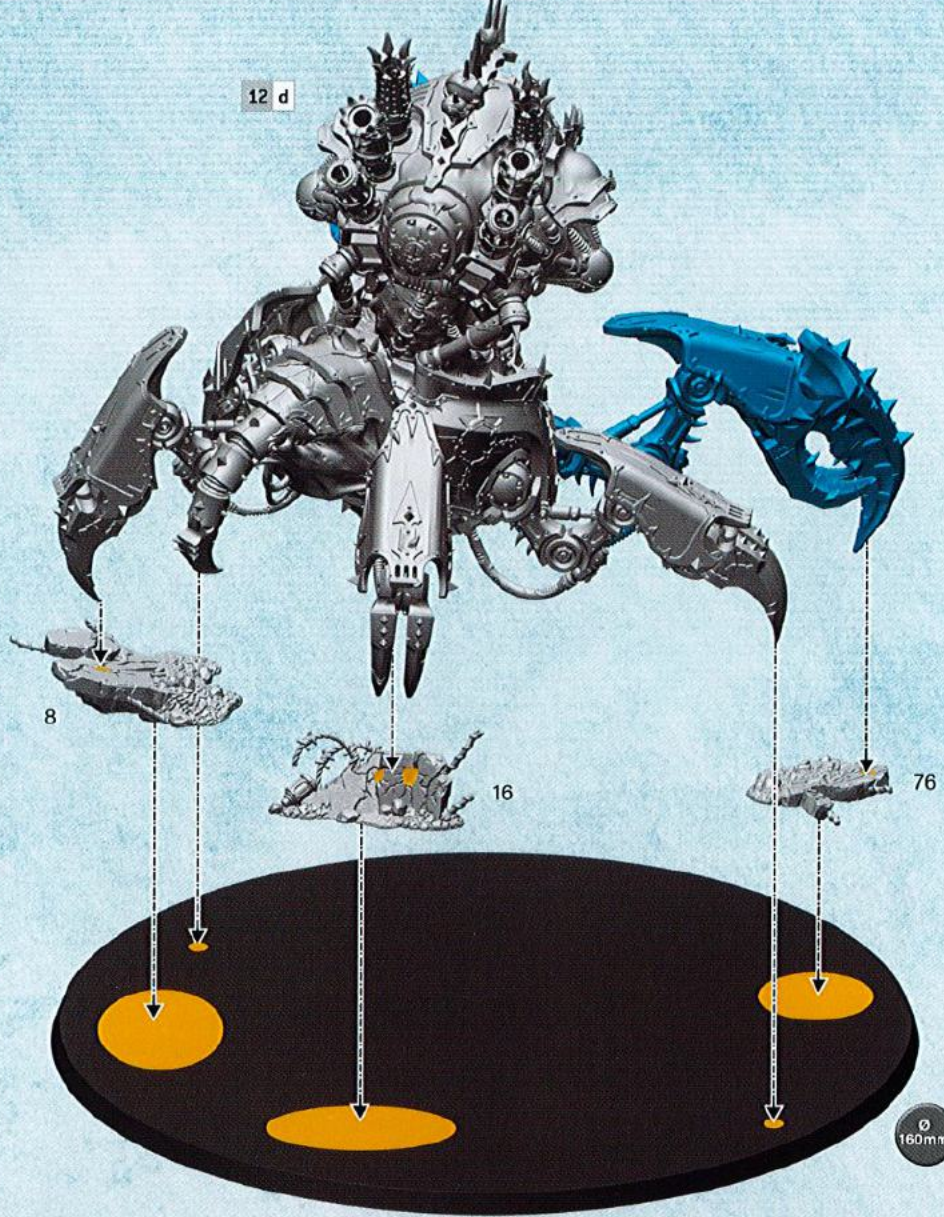

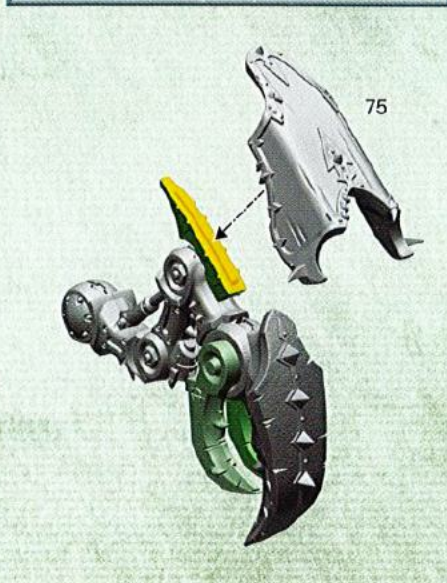
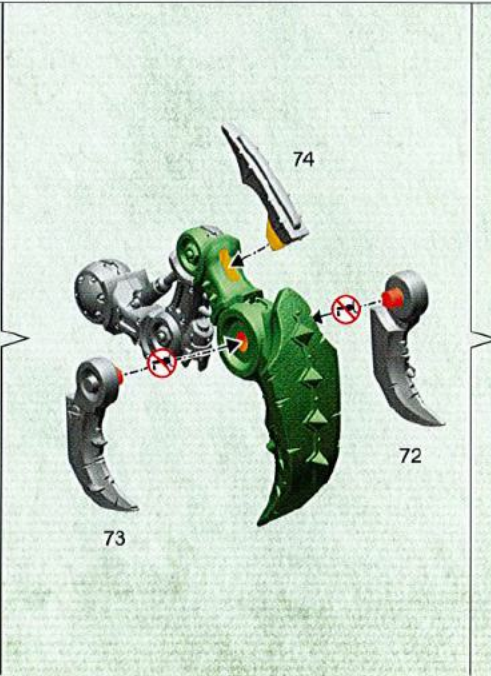
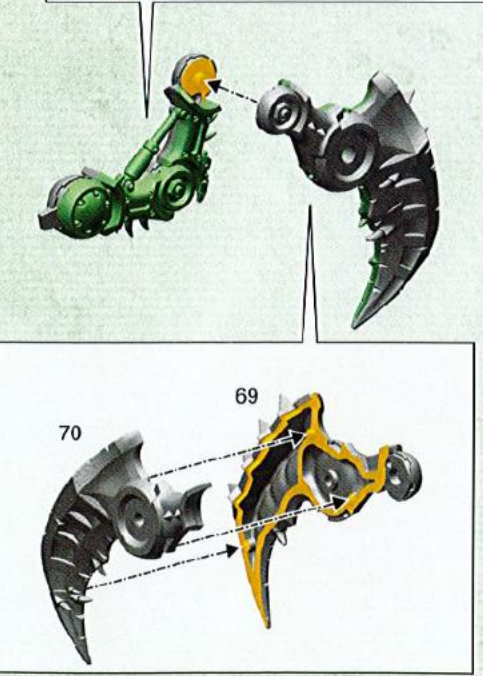
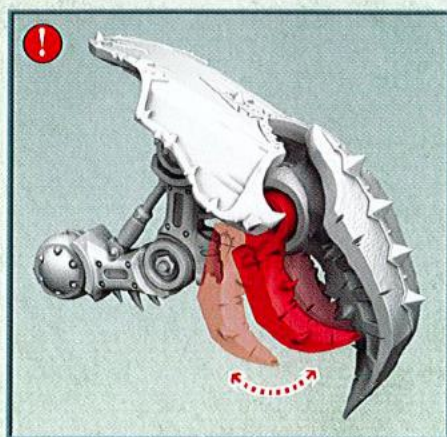
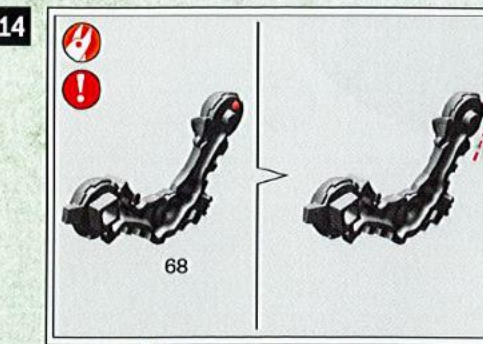
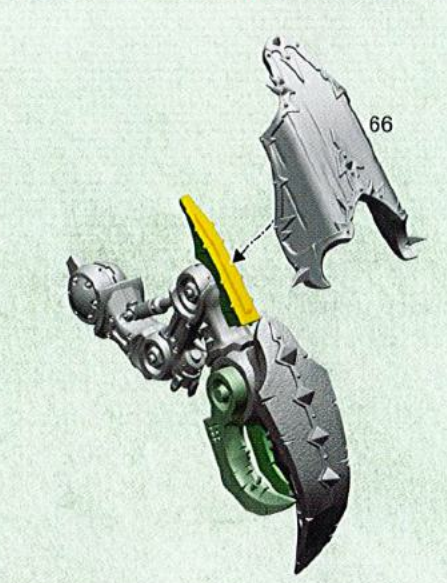
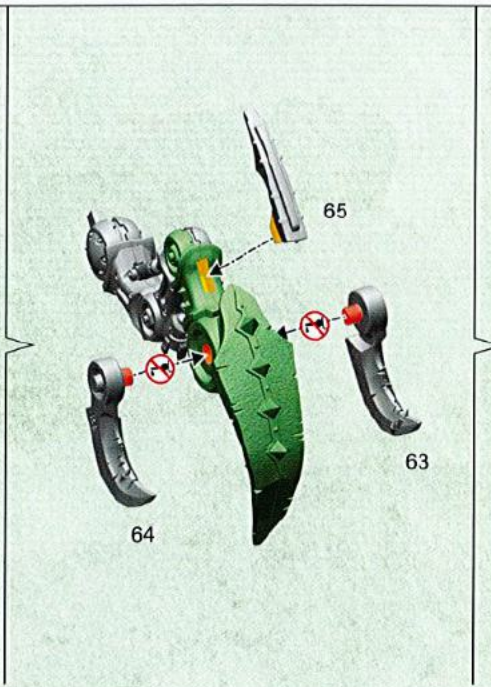
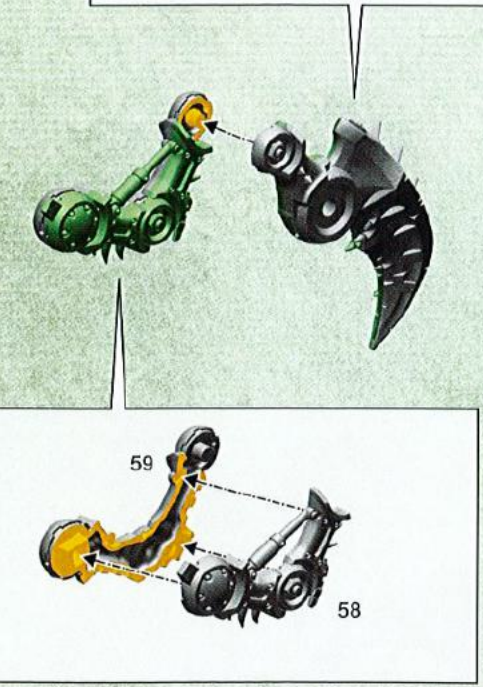
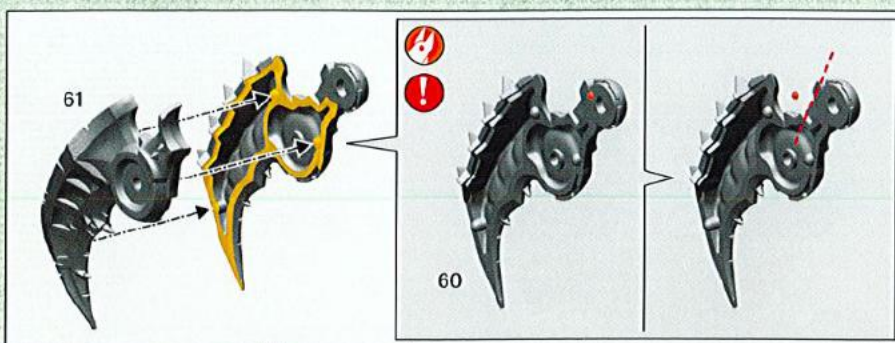

15

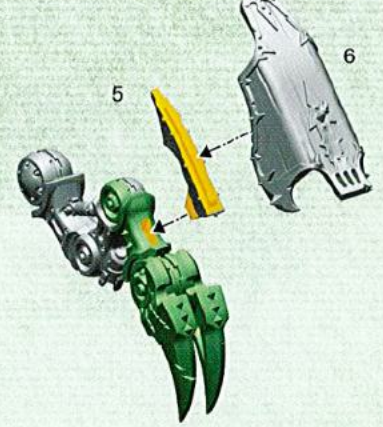
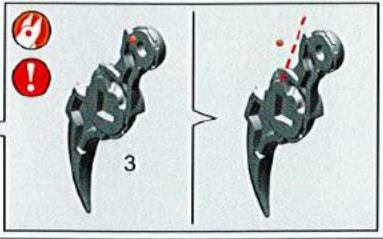
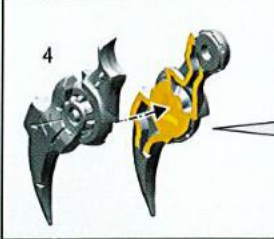
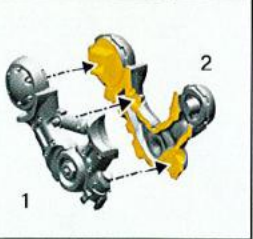
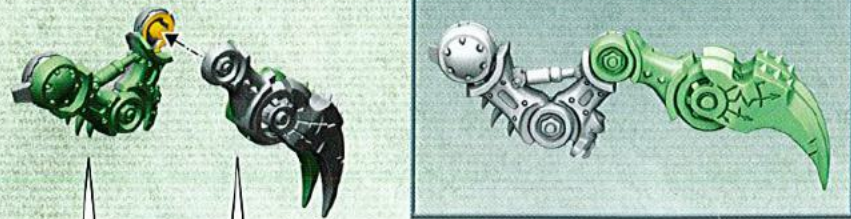

16

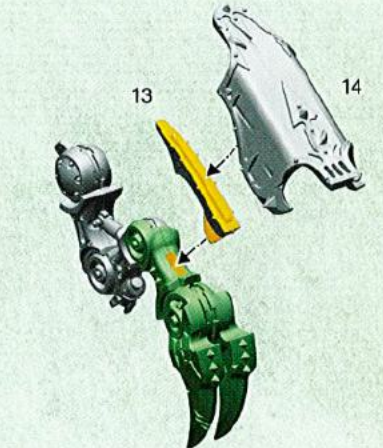
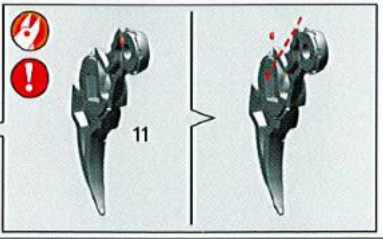
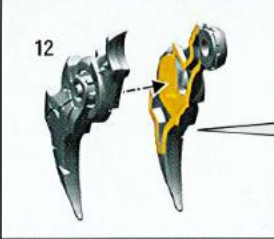
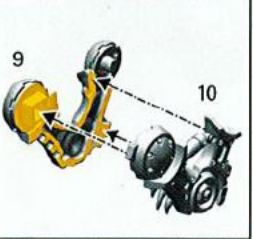

17

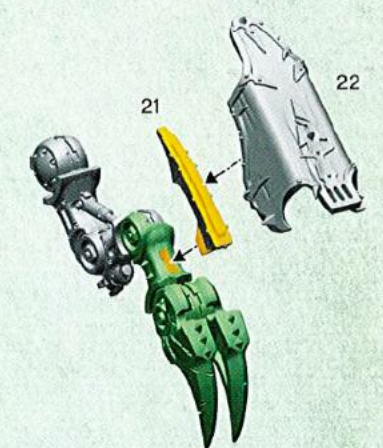
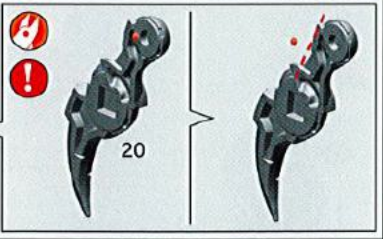
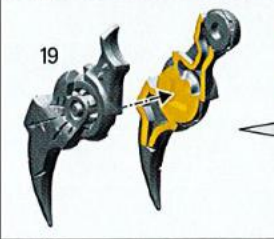
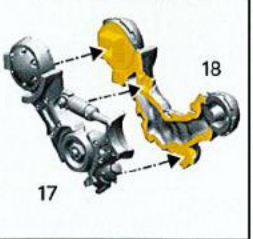
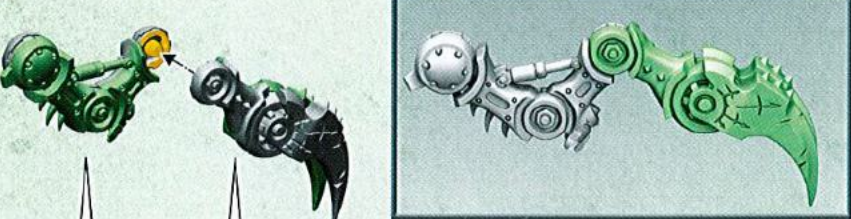

18

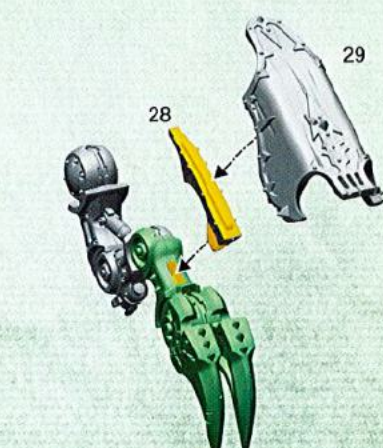
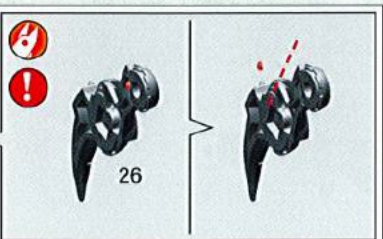
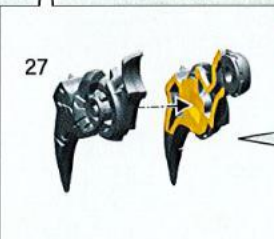
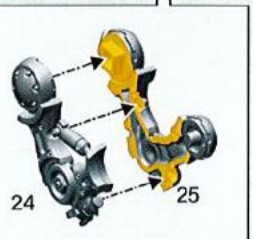

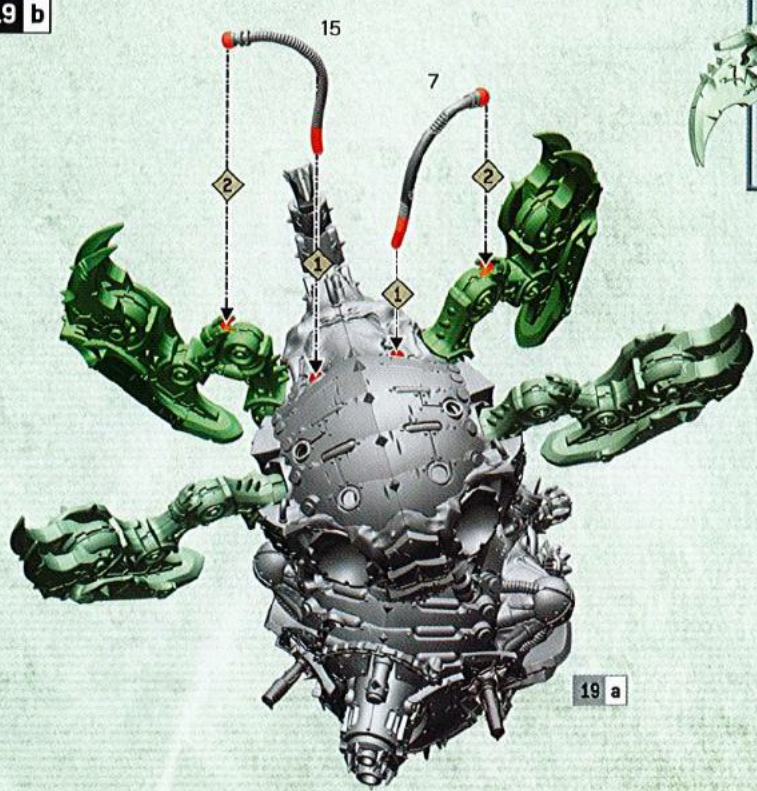
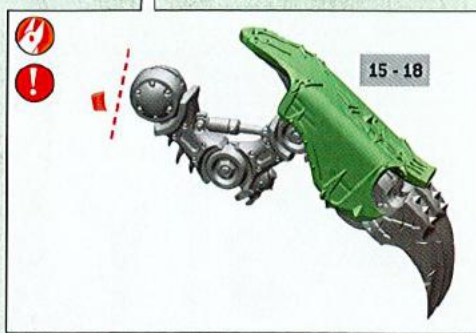
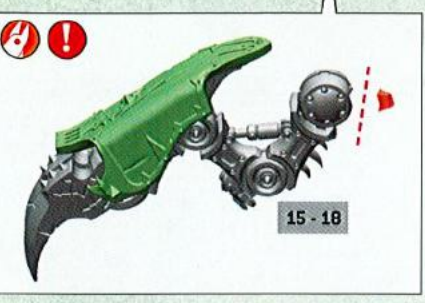
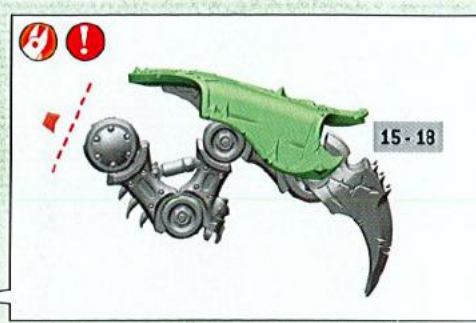
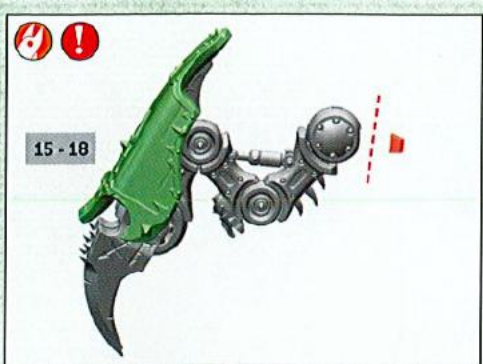

19 a

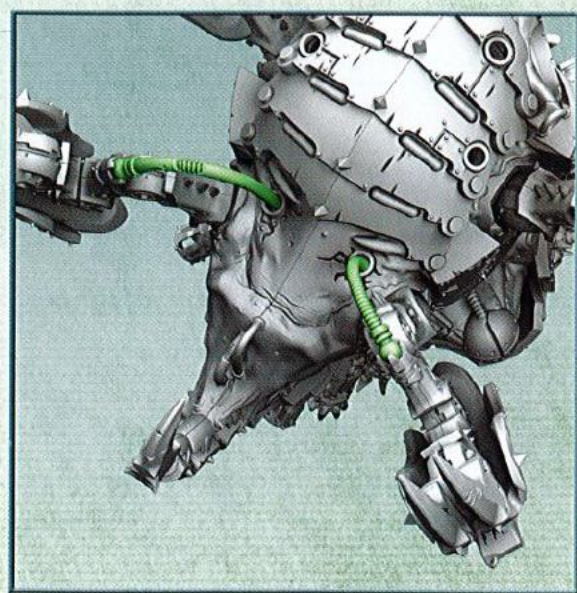
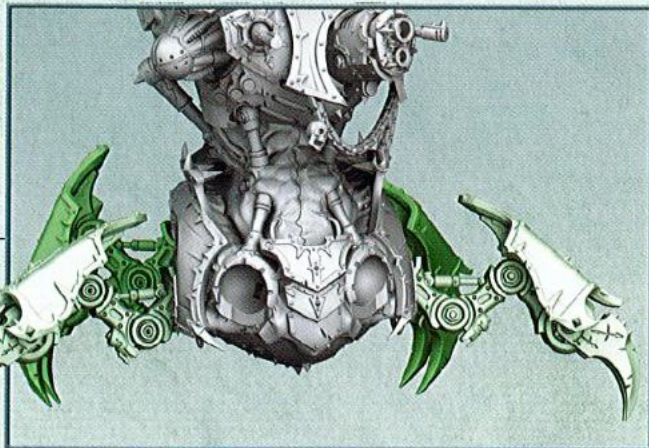

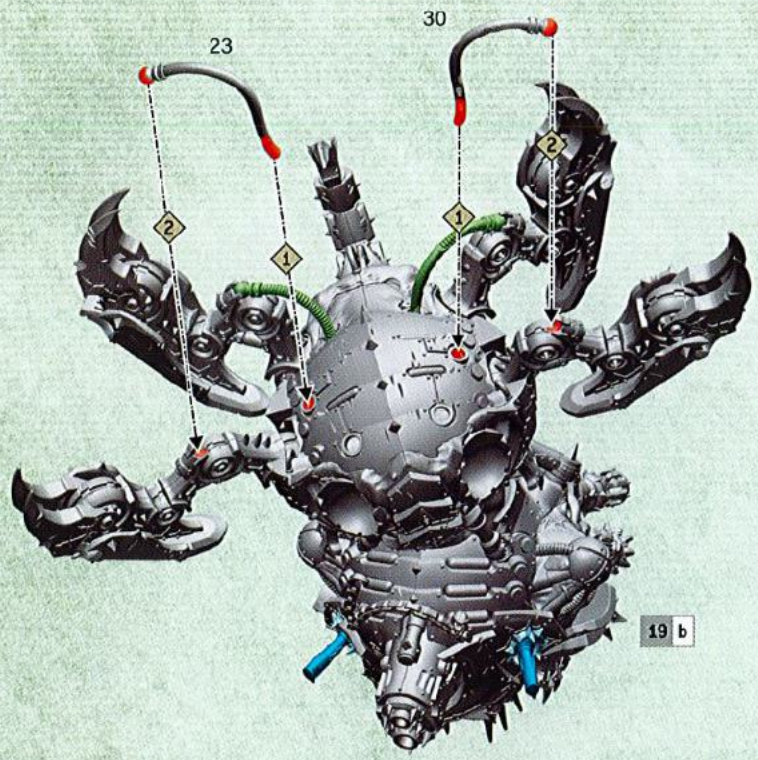
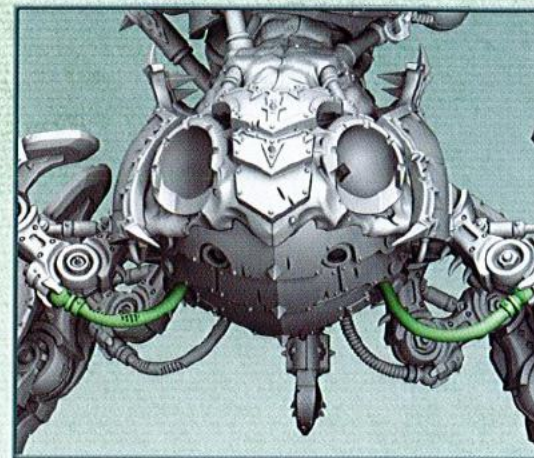

19 b

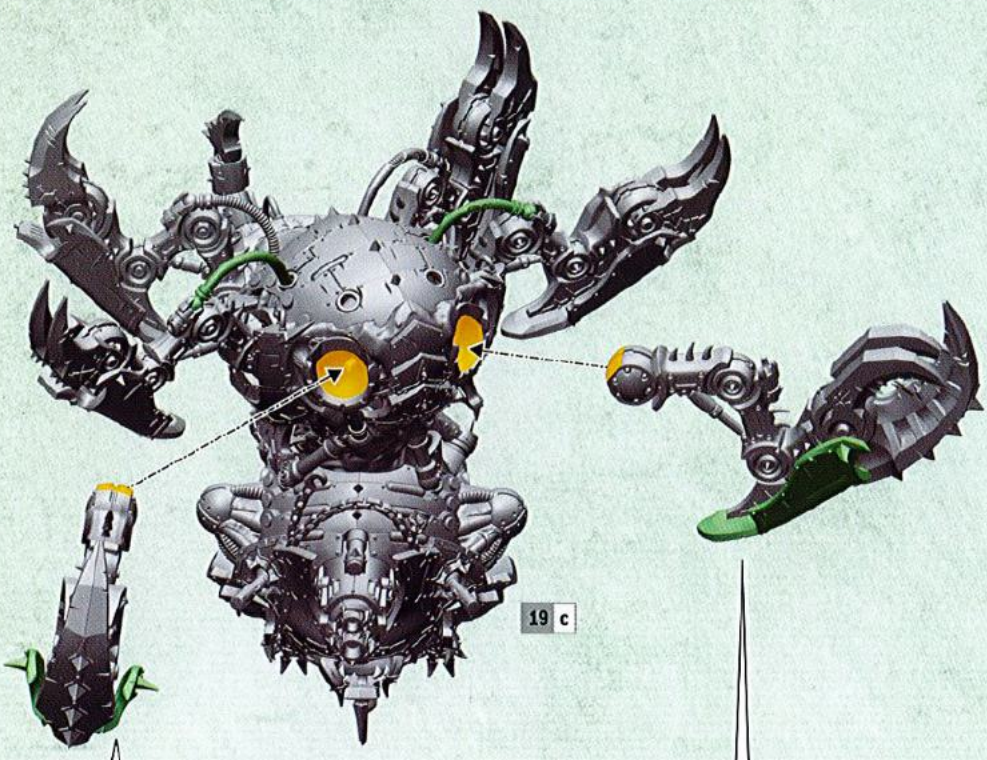

19 c

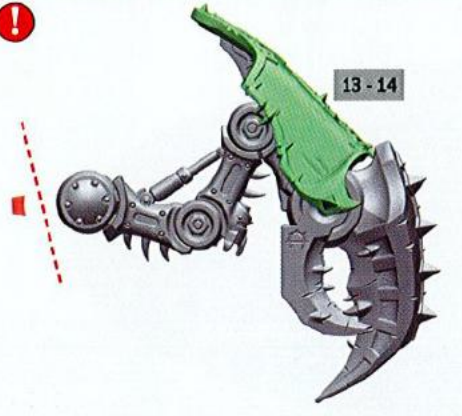

13 - 14



13 - 14

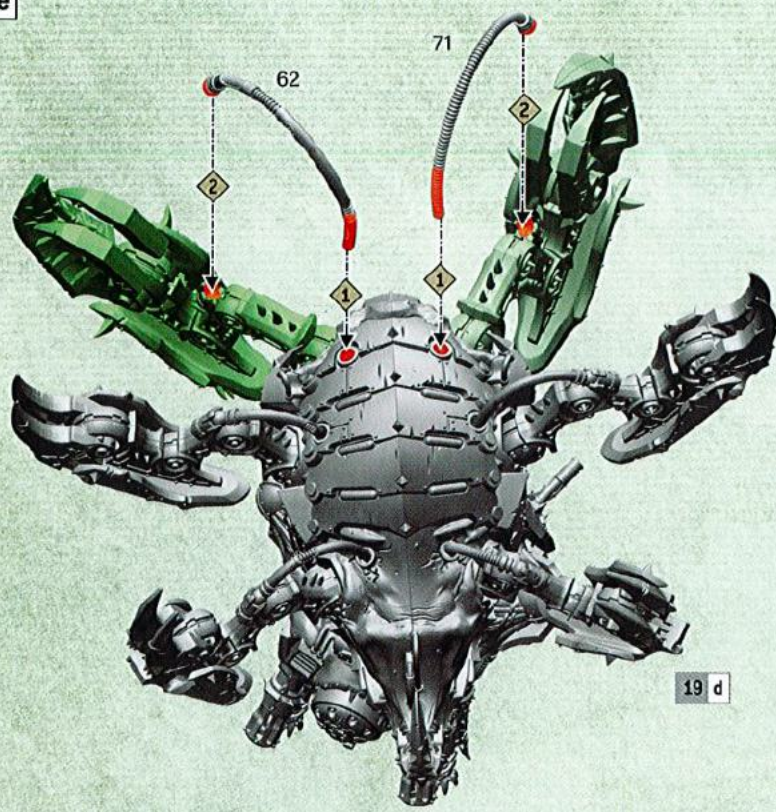

19 d

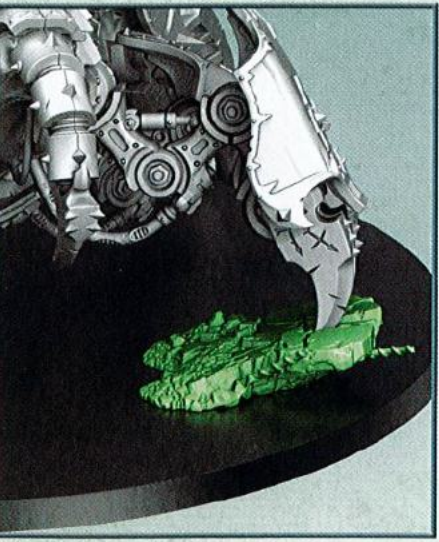

19 e

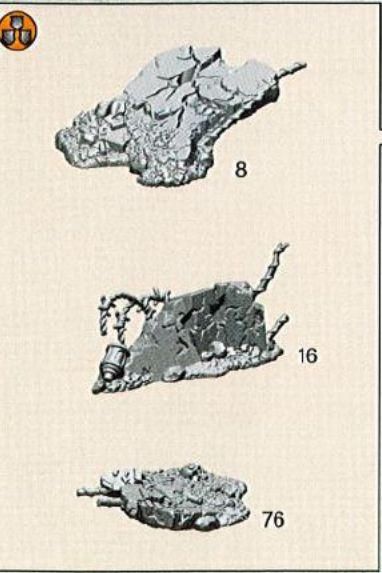

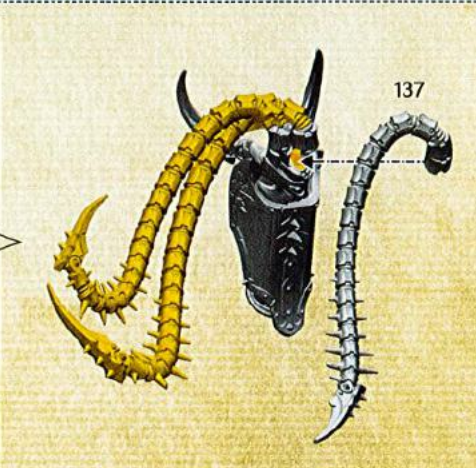
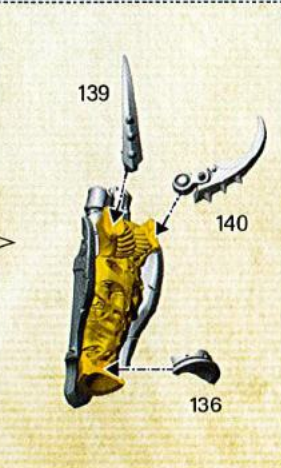
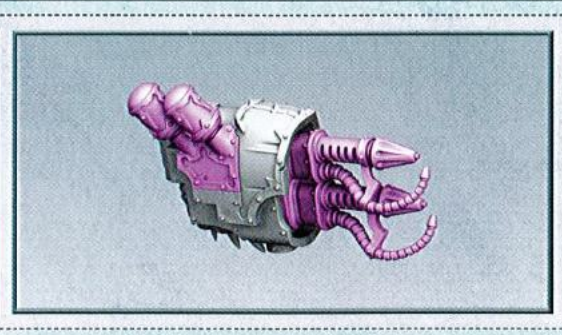
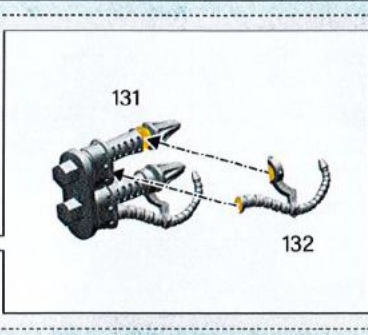
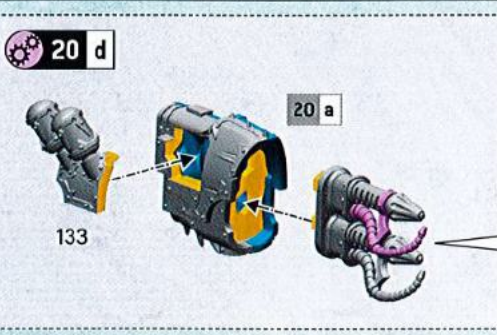
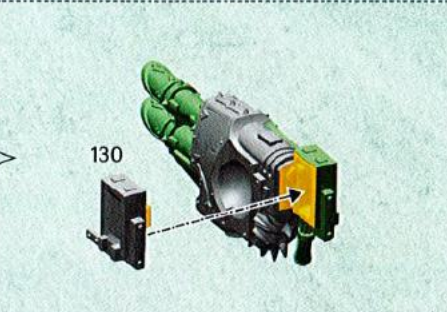
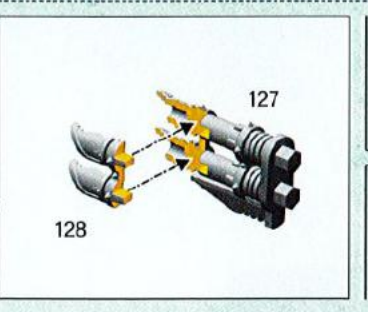
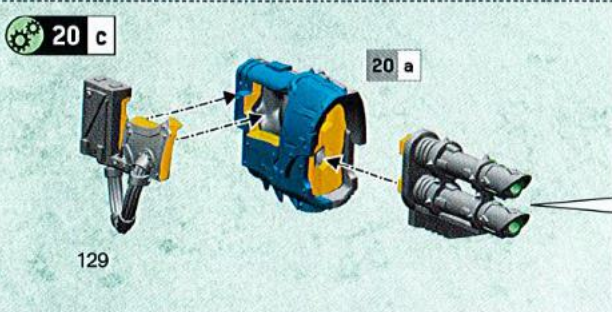
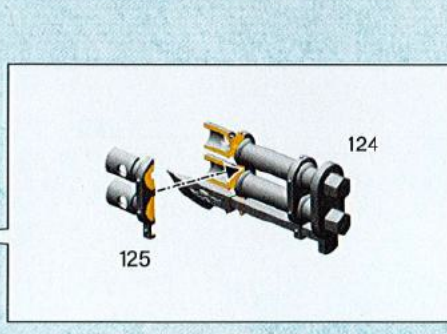
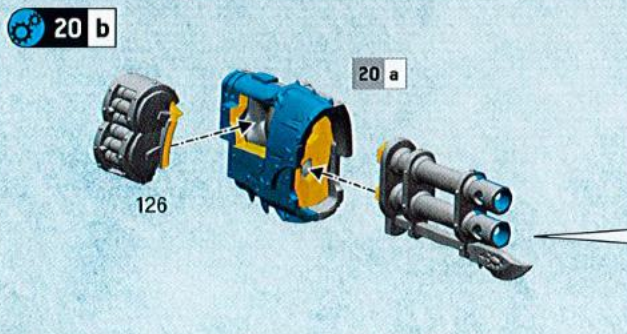
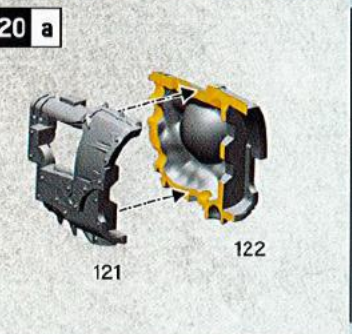
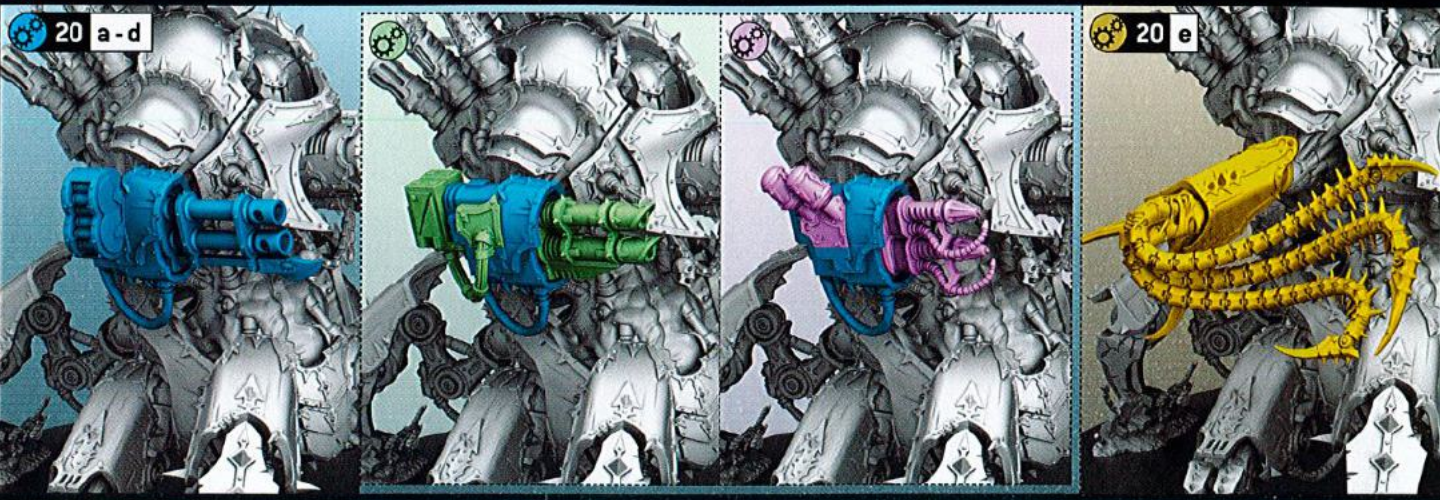

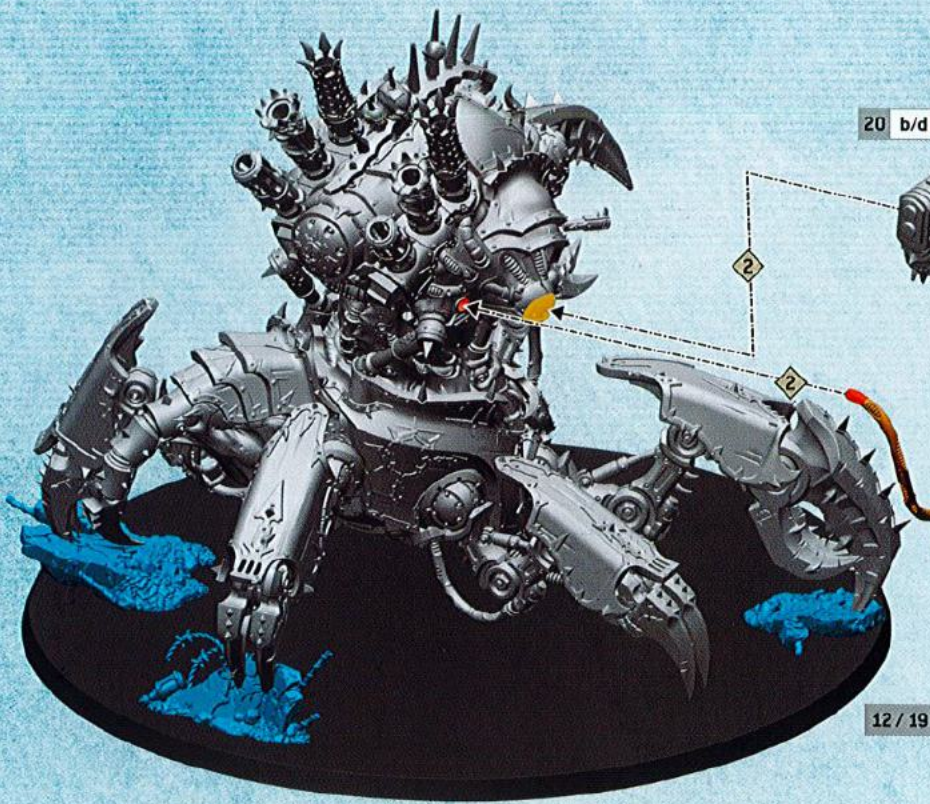

20 b/d

2

2

1



12 / 19



141

123

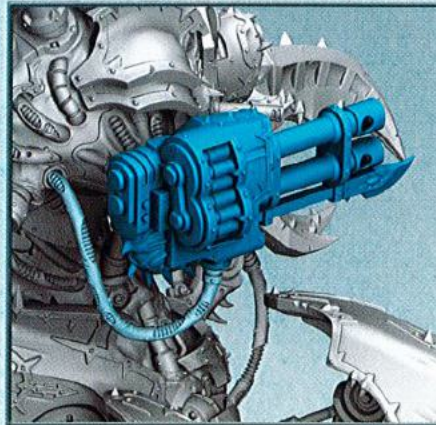

20 e

141

12 / 19



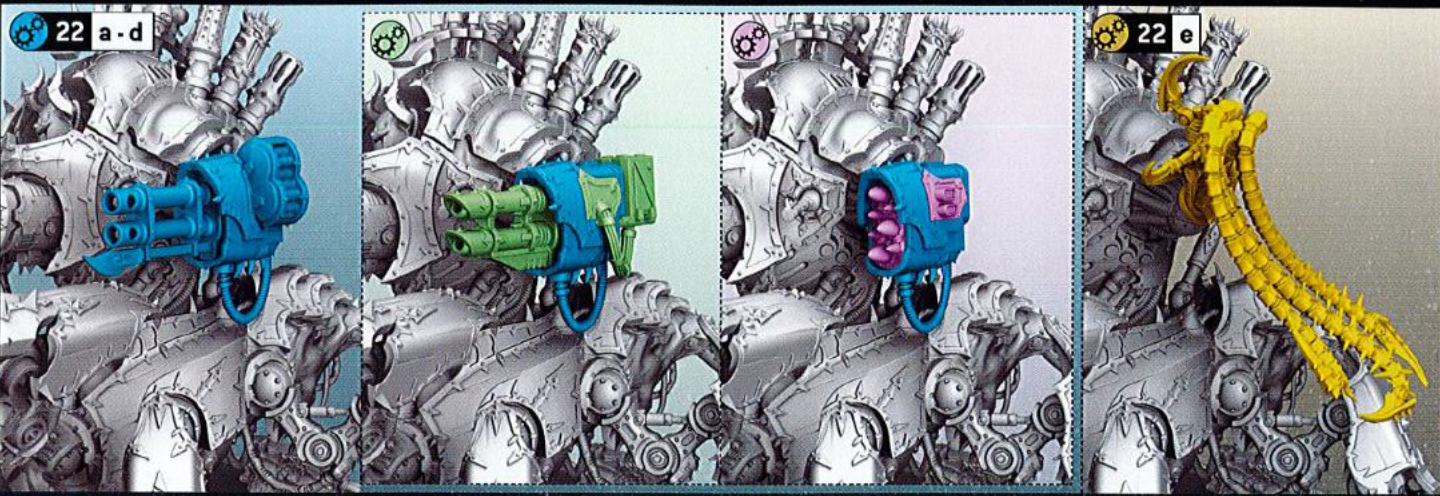

22 a

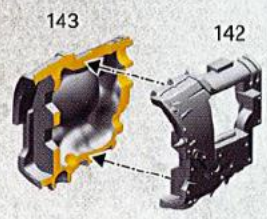

22 b

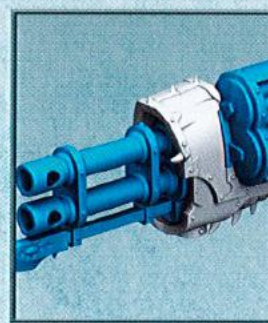
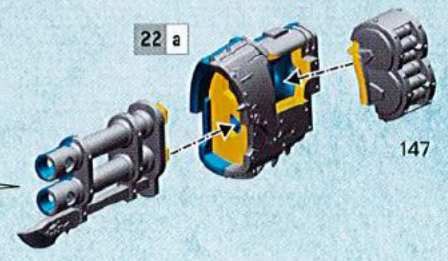
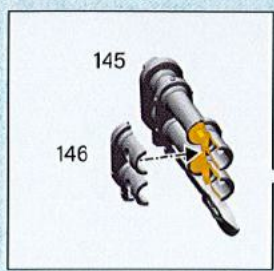

22 c

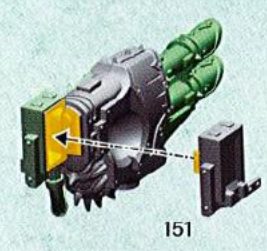
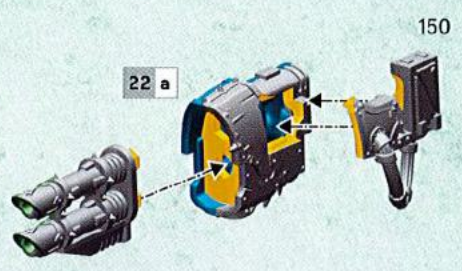
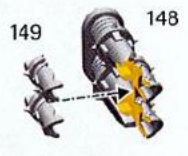

22 d

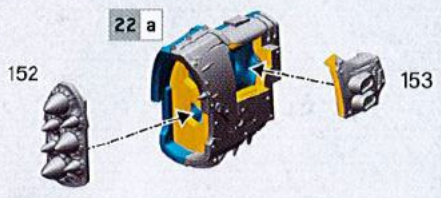

22 e

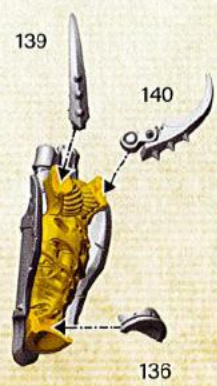

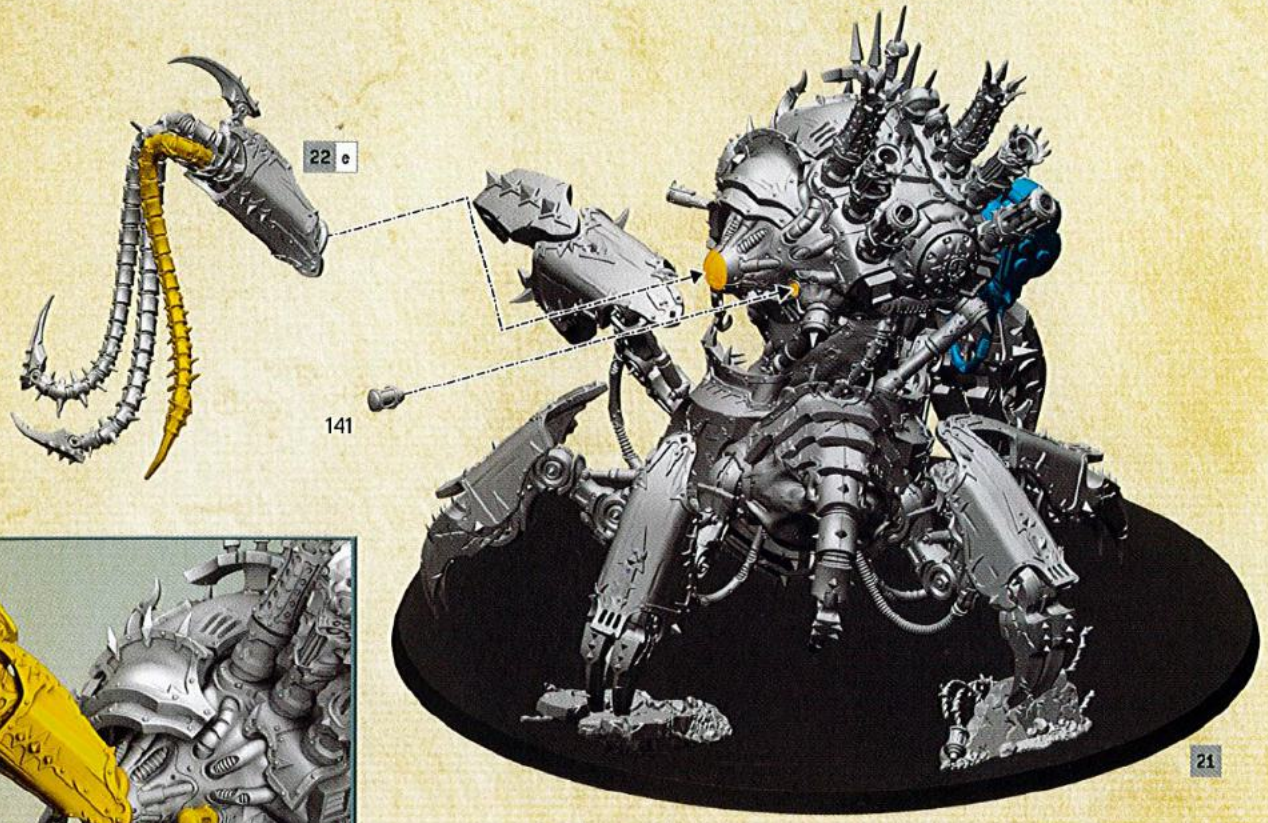
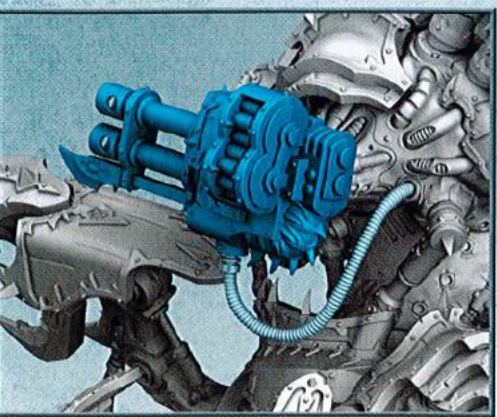
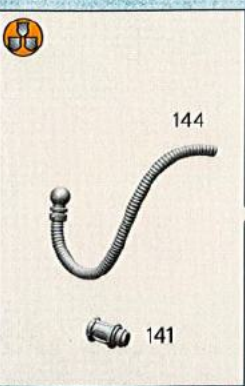

57



56

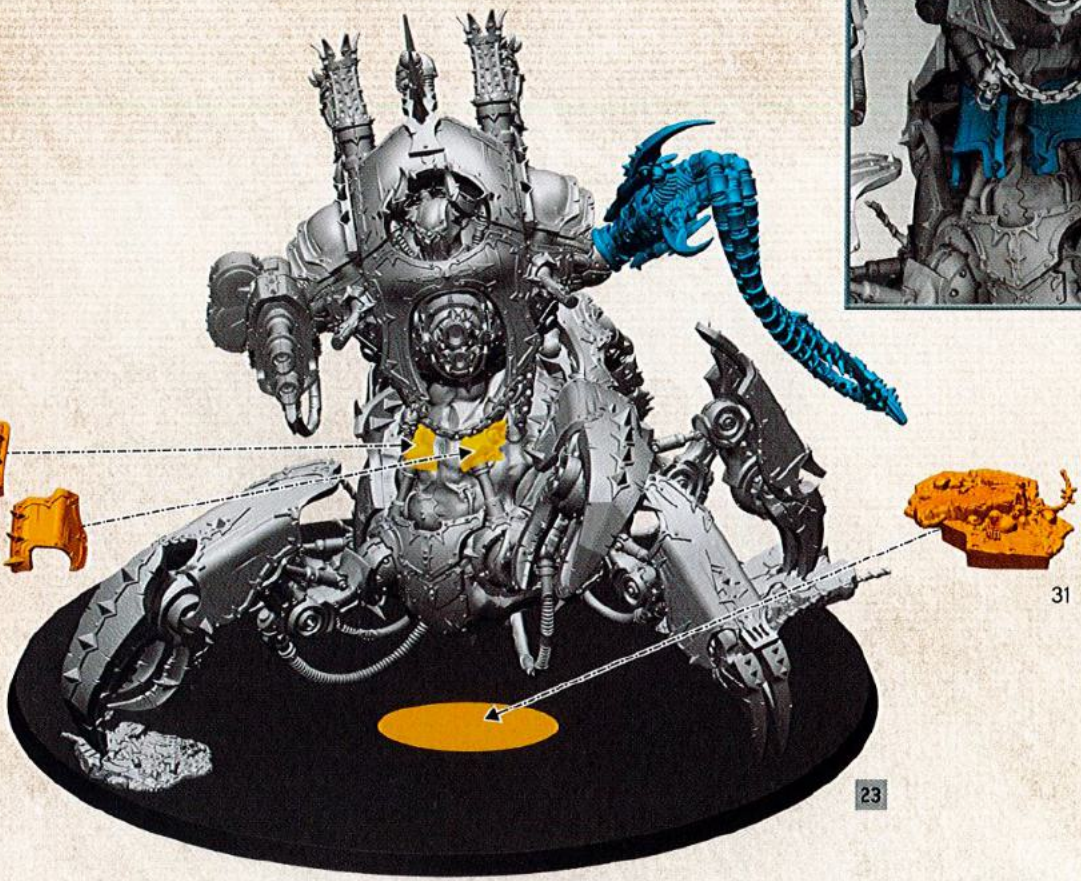

31

23

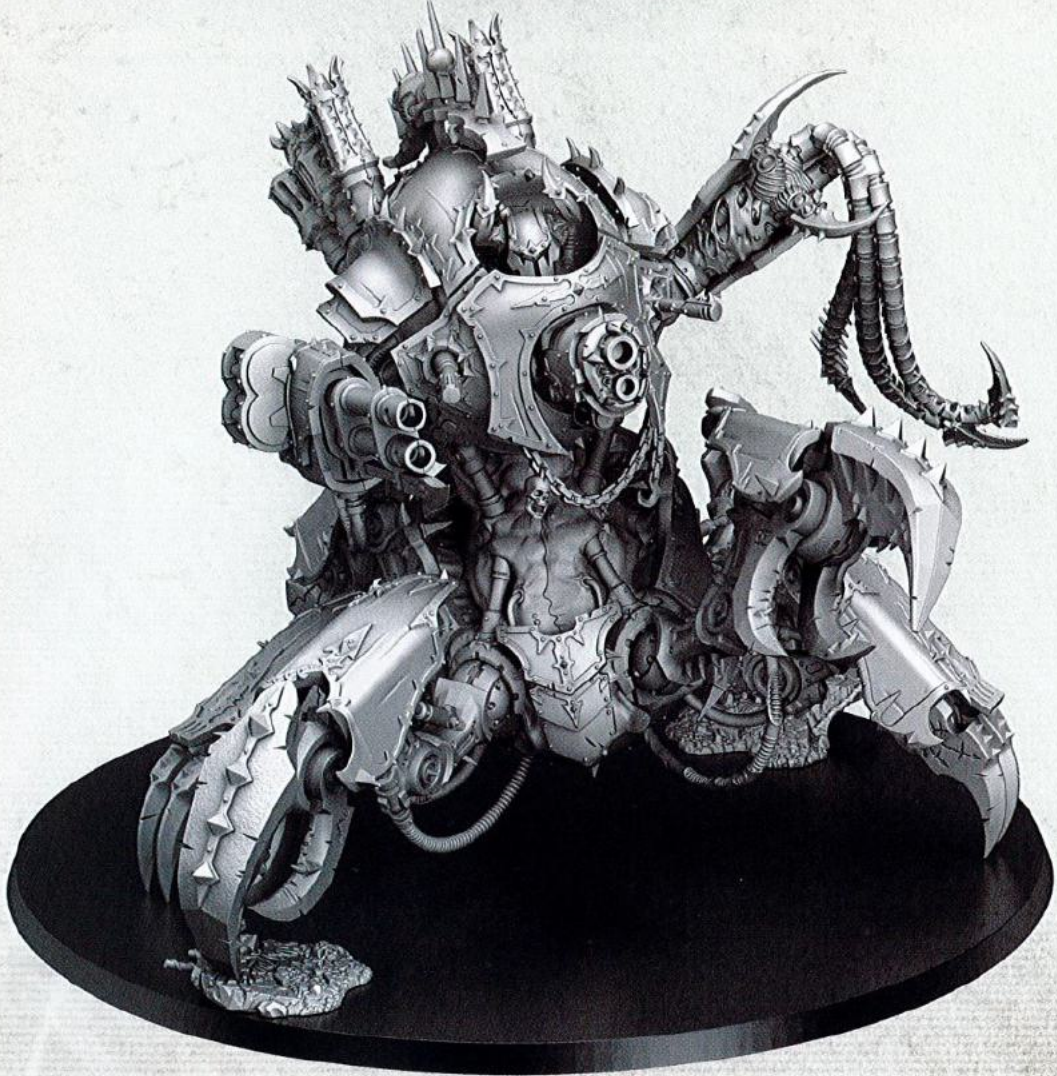
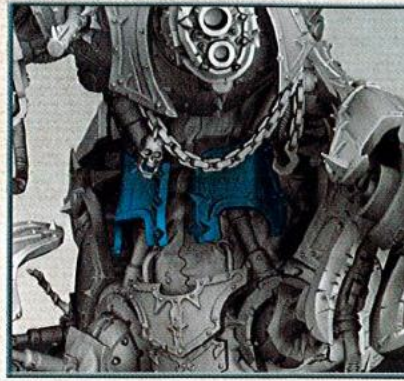

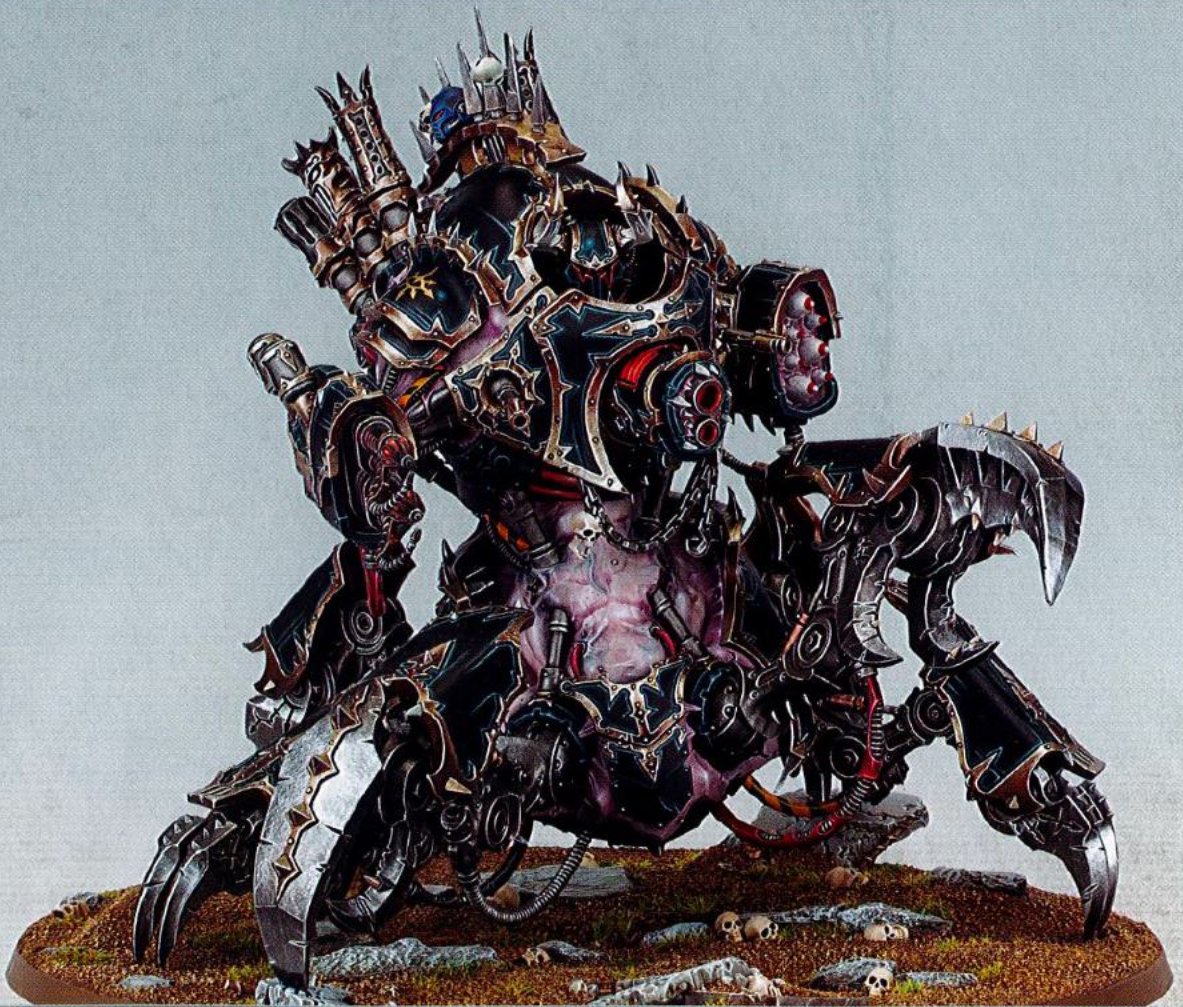
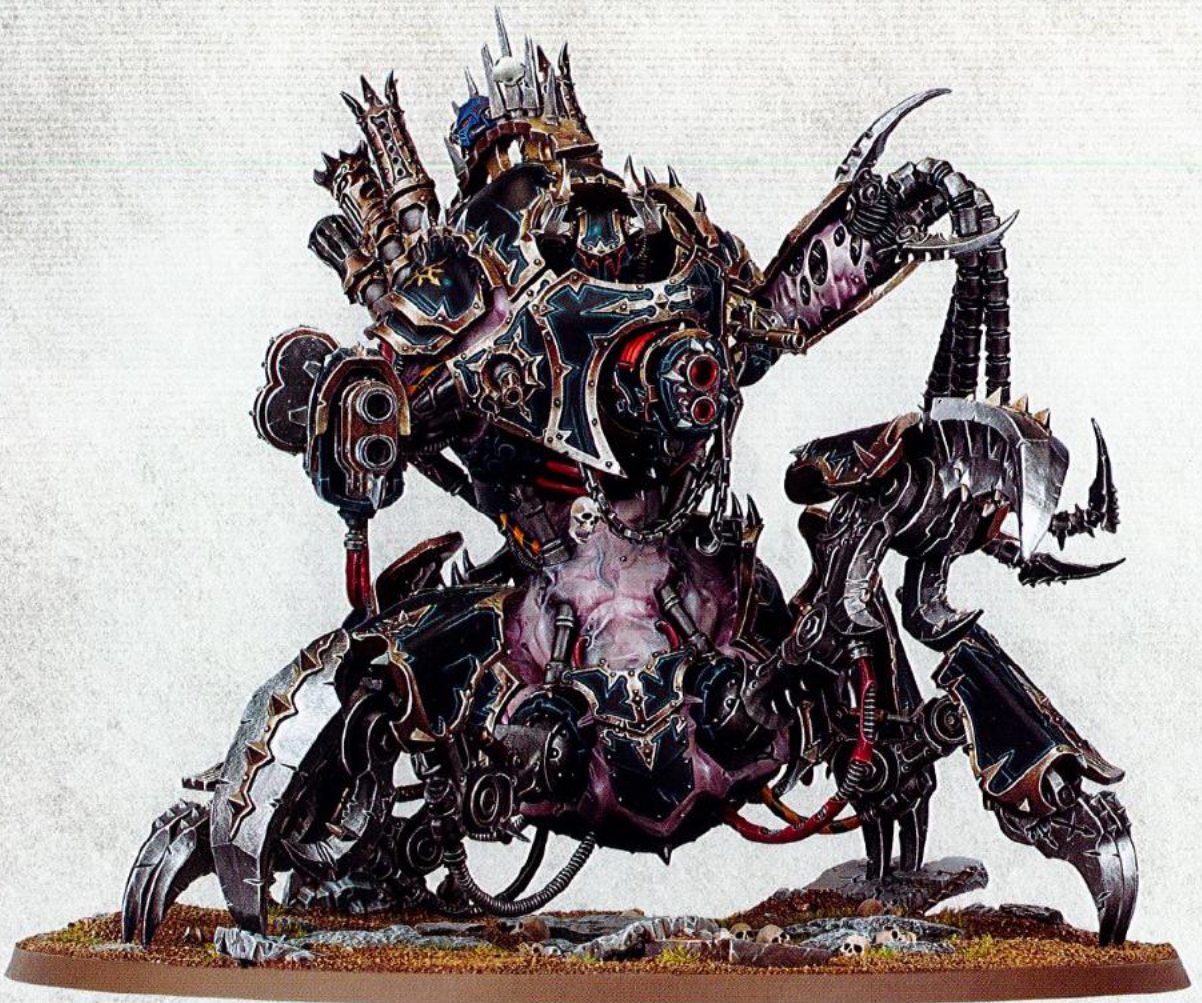

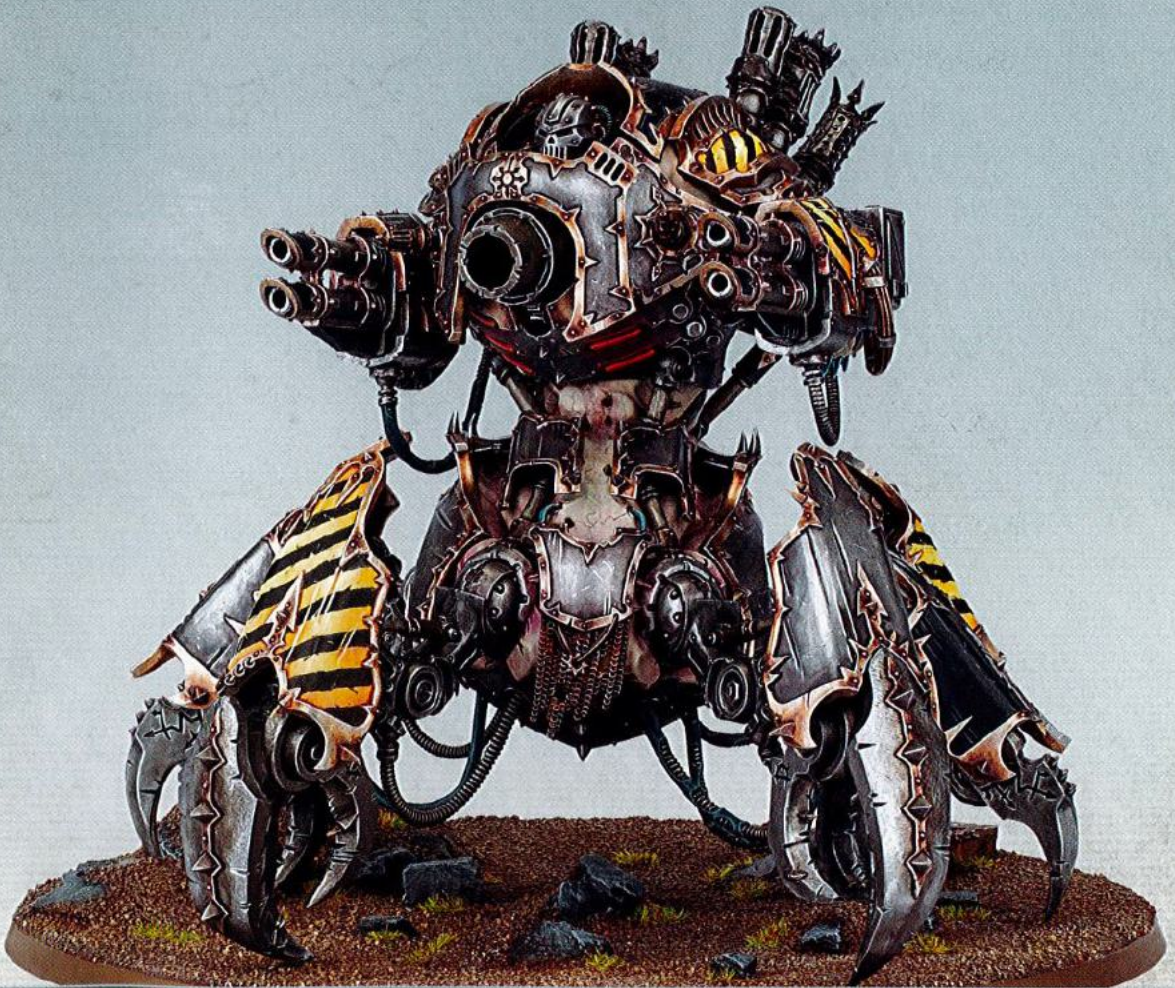

ENG Used alongside the core rules found on warhammer40000.com, the following essential rules will get your new unit on the battlefield. For the full rules for this unit, see the Codex relevant to your army.

FRE Utilisées avec les règles de base disponibles sur warhammer40000.com, les règles essentielles qui suivent vous permettront de jouer votre nouvelle unité. Pour connaître les règles complètes de cette unité, consultez le Codex correspondant à votre armée.

SPA Usadas junto con las reglas básicas que encontrarás en warhammer40000.com, las siguientes reglas esenciales te permiten desplegar esta nueva unidad en el campo de batalla. Para ver las reglas completas de esta unidad, consulta el Codex correspondiente a tu ejército.

GER Mit den Grundregeln auf warhammer40000.com und den folgenden grundlegenden Regeln kannst du deine neue Einheit direkt auf das Schlachtfeld führen. Die vollständigen Regeln für diese Einheit findest du im Codex deiner Armee.

ITA Con le seguenti regole base che puoi trovare su warhammer40000.com, potrai schierare in campo la tua nuova unità. Per le regole complete di questa unità vedi il codex della tua armata.

日英 warhammer40000.com に掲載されているコアルールと一緒に使用することで、以下の簡易版ルールでこのユニットを戦場で使用することができます。このユニットの完全版ルールについては、アーミーに対応したコデックスを参照してください。

中 与 warhammer40000.com 上的核心规则一起使用，以下基本规则适用于您在战场上的新单位。有关该单位的完整规则，请参阅与您的军队相关的经典。

DEFILER

PROFANATEUR | PROFANADOR | GEISSEL | PROFANATORE | ディファイラー | 汚染者

12" 11 3+ 18 6+ 6

5+

1	[BLAST]	48"	D6+3	3+	10	-1	3
2	[BLAST]	36"	D6	3+	12	-3	3
3		36"	6	3+	6	-1	2
4	[MELTA 2]	12"	2	3+	9	-4	D6
5	[IGNORES COVER] [TORRENT]	12"	D6+3	N/A	7	-2	2
6		48"	2	3+	14	-3	D6+2
7	[DEVASTATING WOUNDS] [SUSTAINED HITS 1]	48"	4	3+	9	-1	3
		48"	2	3+	10	-2	D6+1
8	[BLAST]	48"	2D6	3+	5	-1	1
	[BLAST][INDIRECT FIRE]	48"	D6+3	3+	8	0	1

9			5	3+	16	-3	D6+1
			10	3+	6	-2	1
10	[EXTRA ATTACKS] [SUSTAINED HITS 1]		6	3+	12	-2	2

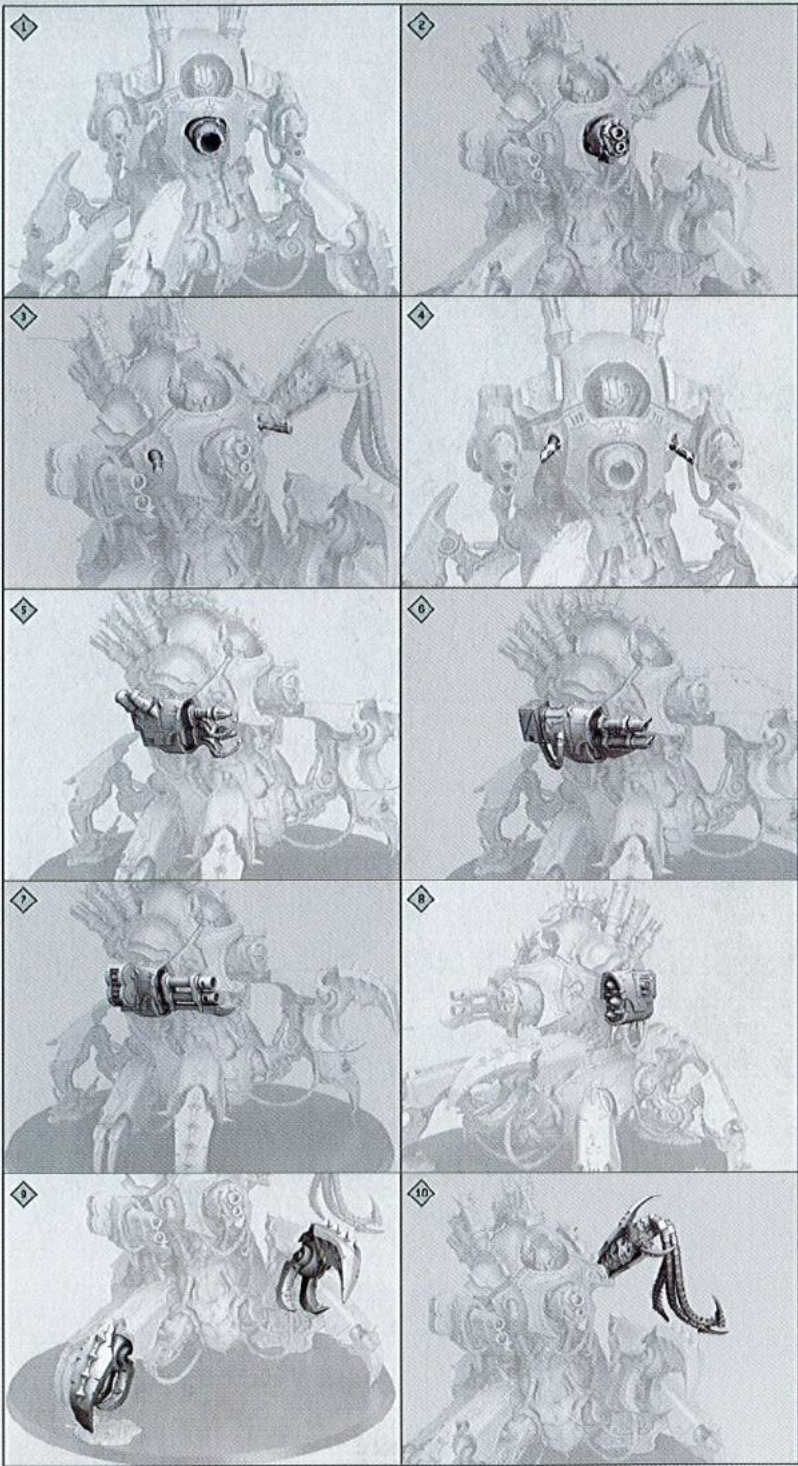

FR **DONNEZ** OU **RECYCLEZ** ASSOCIATION MAGASIN DÉCHÈTERIE

Adresses sur quefairemesdechets.fr



WARHAMMER.COM

Games Workshop Limited, Willow Road, Nottingham, NG7 2WS, UK
© Copyright Games Workshop Limited 2026.